

## ⚠ Important Safety Notice ⚠

It is the responsibility of the person installing the electrical equipment to ensure that the installation meets the requirements of the IET wiring regulations and is therefore 'fit for purpose'. Factors such as correct selection of components, cable sizing, protective devices and Earth bonding are all critical and should be checked prior to full testing and power-up. Any other regulations applicable to the equipment being installed such as the Machinery Directive and current health and safety legislation must also be adhered to.

Terminals, including factory fitted, should be checked periodically to ensure correct tightness.

**DO NOT USE POWER TOOLS ON THESE PRODUCTS**



KEMA Certified  EN 60947-1 & 3 Compliant  IP65



Data	Range	Units	LBC1603PSNME	LBC2003PSNME	LBC2503PSNME
Rated thermal current $I_{th}$ at 40°C	Amps	A	160	200	250
Rated insulation voltage $U_i$	Volts	V	1000	1000	1000
Rated dielectric strength	Volts	kV	4	5	5
Rated impulse voltage $U_{imp}$	Volts	kV	8	8	8
Rated operational current $I_e$ at 400V AC-22	Amps	A	160	200	250
Rated operational current $I_e$ at 400V AC-23	Amps	A	160	160	160
Rated operational power $P_e$ at 400V AC-23	Watts	kW	89	89	89
Rated breaking capacity	Amps	A	1280	1280	1280
Rated making capacity	Amps	A	1600	1600	1600
Rated short circuit making capacity (peak value) $I_{cm}$	Amps	kA	13	13	13
Rated short-time withstand current (1 sec) $I_{cw}$	Amps	kA	7	7	7
Minimum number of mechanical operations	-	Cycles	10,000	10,000	10,000
Minimum number of electrical operations @ 400V AC-22	-	Cycles	1,000	1,000	1,000
Terminal Capacity (rigid copper cable)	-	mm <sup>2</sup>	95	120	120
Lug bolt size	-	-	M10	M10	M10
Maximum size of busbar connection	-	mm	5x30	5x30	5x30
Tightening torque	-	Nm	13	13	13

**Enclosure Dimensions**

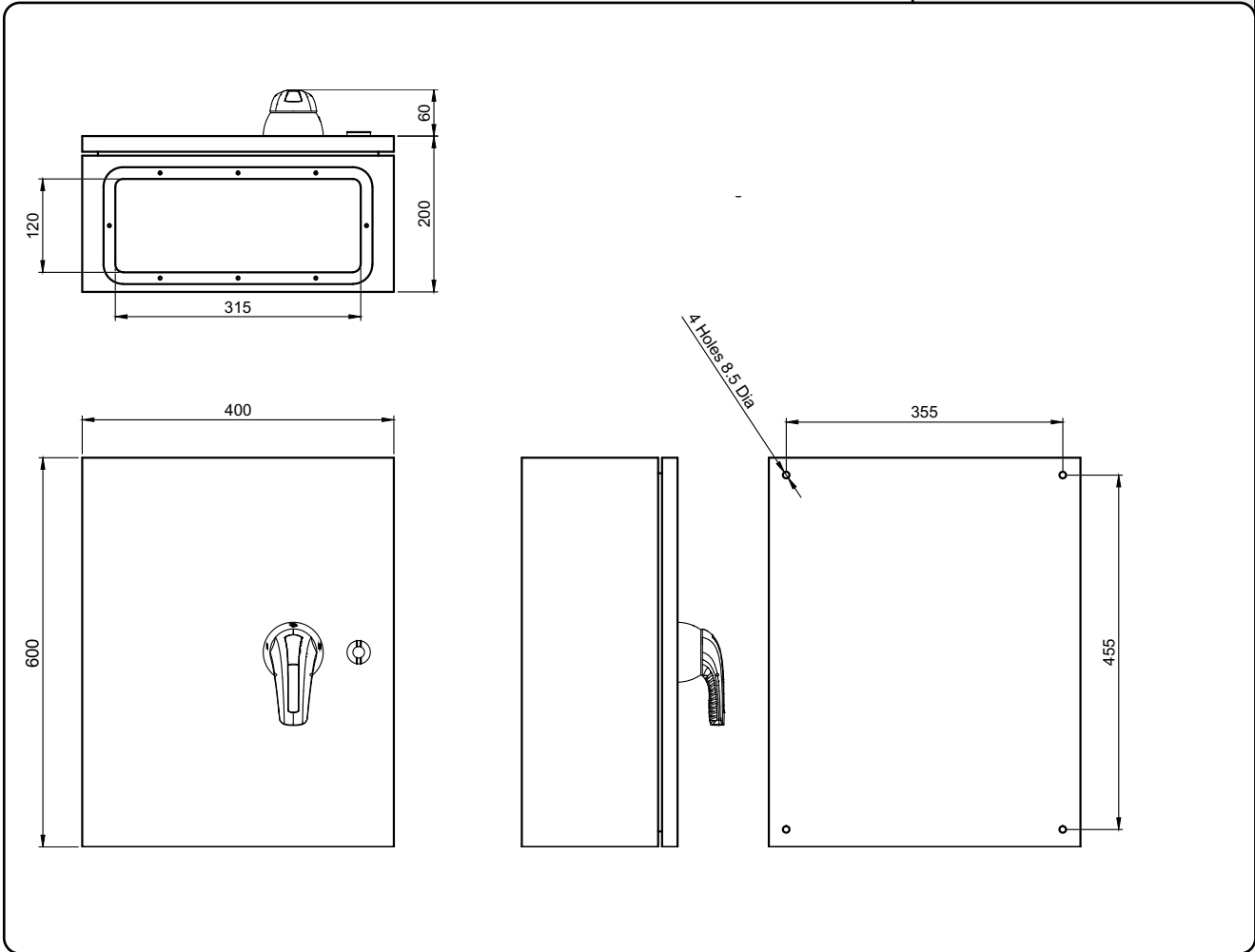

**Terminal Configuration**

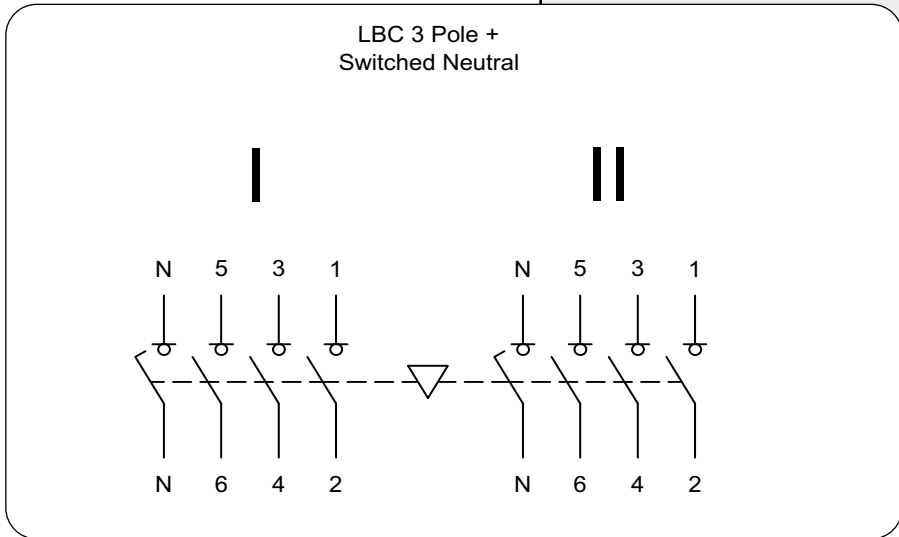



### Handle Assembly:

1. Ensure that the handle is in the off position and locate the handle on to the door with the handle showing the off position at 12 o'clock
2. Tighten the four M5 flange nuts to 1.5Nm



### Shaft Assembly:

3. Ensure that the switch is in the off position and fully insert the shaft into the switch with the cross pin in a vertical position
4. Tighten the M5 shaft grub screw to 1.2Nm using a 2.5mm A/F allen key

### Padlock Operation:

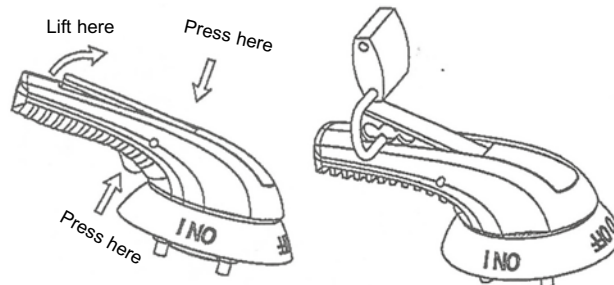

### Door Interlock Defeat Mechanism (For Authorised Personnel Only):

#### **⚠ WARNING! ACCESS TO LIVE PARTS**

- Ensure that the door is closed and the handle is in the on position
- Locate the hole on the right side of the handle, then push and hold a small pin into the hole to activate the defeat mechanism
- The door can now be opened in the on position. Remove pin and close the door to reset the mechanism

