

Data Sheet : DSL102



Intertek



Electrical & Lighting Products

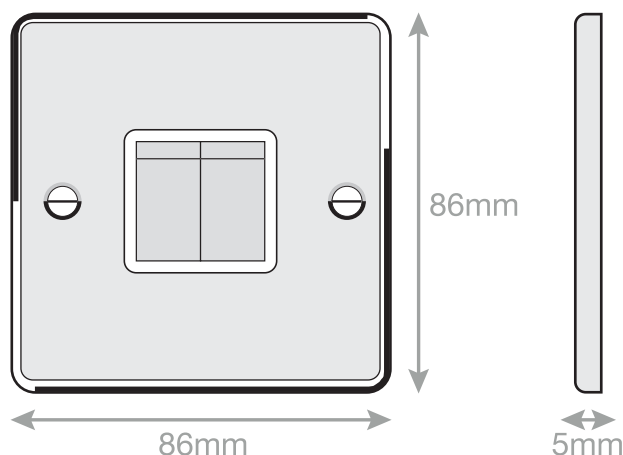

Code	DSL102
Description	10 Amp Plate Switch - 2 Gang 2 Way - X-Rated
Size	86mm x 86mm x 5mm depth
Range	Selectric 5M
Colour	Satin chrome white insert & matching metal rockers
Material	Premium grade steel
Included	M3.5 fixing screws & wiring instructions
Weight	0.14kg
Inner Carton Quantity	10
Inner Carton Weight	1.4kg
Guarantee	5 year plate guarantee
Barcode	5025117981023
Commodity Code	85369085
Standards	BS EN 60669-1
Notes	<ul style="list-style-type: none"> • ASTA approved • Matching metal rockers • X-rated for fluorescent or inductive loads • Modular and Euro Media products available within the range • Minimum back box size required: 16mm depth