

Commissioning

- Refit the cover on the IP terminal block, ensuring that the seals are correctly located.
- If the unit is to be used in a submerged location, seal the unit into position using silicone sealant.
- Push the unit into the hole, and adjust the cable so it does not get snagged.
- Replace fuse or circuit breaker and switch on. Your light is now ready for use.

If the unit is to be fitted in decking or similar, then secure with a couple of spots of silicone sealant.

Fitting/replacing bulbs

- This system contains non-replaceable parts and cannot be serviced. If damage occurs the part should be scrapped.

We recommend cleaning with a soft dry cloth.

Do not use solvents or abrasive cleaners as these could damage the finish.

Recycling advice



Waste electrical products should not be disposed of with household waste. Please recycle where facilities exist. Check with your Local Authority or retailer for recycling advice.

Safety information

For your safety, always switch off the supply before cleaning.

This system contains non-replaceable parts and cannot be serviced. If damage occurs the part should be scrapped.

Instruction leaflet

Cove Recessed LED

67360



CE

saxby
lighting

Thank you for purchasing this light fitting. Please read the instructions carefully before use to ensure safe and satisfactory operation of this product. Please retain these instructions for future reference.

Warning



This light fitting is Double Insulated and does not require connection to an Earth circuit.

Please read these instructions carefully before commencing any work.

This unit must be fitted by a competent and qualified electrician.

Install in accordance with IEE Wiring regulations and current Building Regulations.

To prevent electrocution switch off at mains supply before installing or maintaining this fitting. Ensure other persons cannot restore the electrical supply without your knowledge. If you are in any doubt, please consult a qualified electrician.

This light fitting should be connected to a circuit with a 30mA RCD fitted.

If replacing an existing fitting, make a careful note of the connections.

The unit cannot be dimmed.

Waste electrical products should not be disposed of with household waste. Please recycle where facilities exist. Check with your local authority or retailer for recycling advice.

This product is rated at IP67.

This product is not suitable for location in or near a marine environment.

Please note that the entire unit gets hot whilst on for a period of time.

Installation

Existing fittings must be completely removed before installation of a new product. Before removing the existing fitting, **carefully note the position of each set of wires.**

- After deciding the layout of the light fittings, and the position of the junction box, ensure the cables are long enough to connect to the desired positions.

Ensure that there is some slack cable to allow removal of the unit

- Cut a 32mm diameter hole in the mounting surface. The hole must be at least 50mm deep to allow the product to sit properly. Take care not to damage any pipes or cables beneath the mounting surface. Ensure that adequate room is left for the cable.
- Feed the cable of each unit through the mounting holes and check the fit of the unit in the hole.

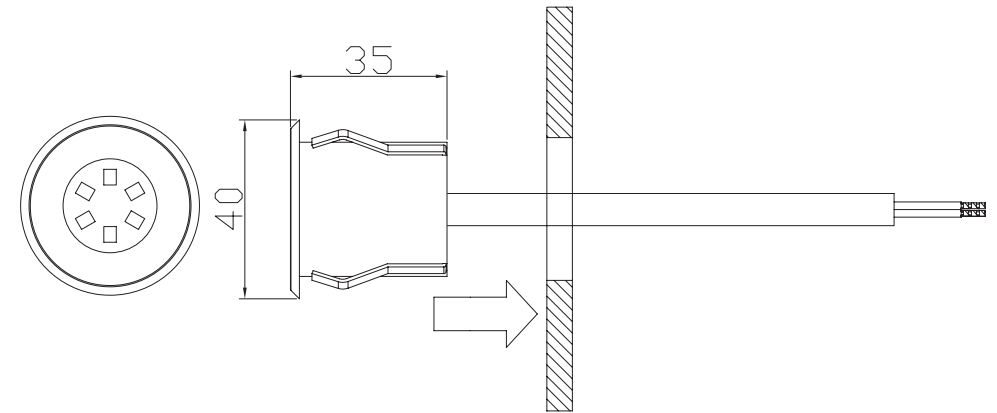

Specification

Voltage: 240V ~ 50hz
Lamp: 0.3W LED Module (SMD 3528) Cool White - 35lm
IP rating: 67
Temperature Range: -20 to +40 degrees C

Layout

- Plan the desired layout of this fitting carefully, ensuring the cables will reach the distance between the junction box and the light fitting.
- Avoid locating any cables in positions that would cause a hazard. Position cables and outdoor rated junction boxes (not supplied) away from areas where they may be at risk from being cut, trapped or damaged.
- Suitable outdoor cables must be used and protected using suitable conduit or plastic trunking.
- We recommend that you use H05RN-F specification cable (not supplied) which is an outdoor grade, rubber sheathed cable. The mains supply cable must have a minimum cross sectional area of 1.0mm²

Wiring

Having correctly identified the wiring from your existing light fitting, connect to the approved outdoor rated or approved double insulated terminal block in the following way:

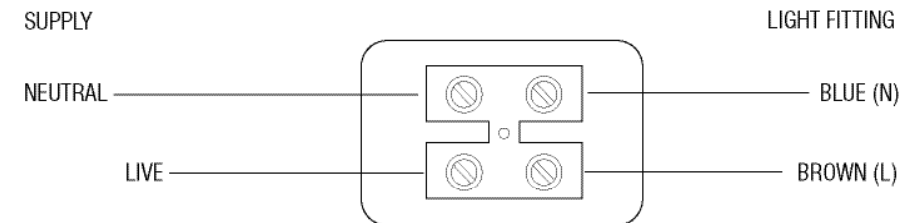

Check that...

- You have correctly identified the wires.
- The connections are tight.
- No loose strands have been left out of the connection block.