



REDRING

Showering and hot water solutions **2011/12**

Redring

Showering and hot water solutions

Welcome

Designed with speed in mind and sized so that you can keep it close-to-hand, this pocket guide is packed with all the information you should need to choose the right **Redring** product. Every page contains a brief overview of what the product does, its key features, plus all the other information you may require to ensure specification of the right **Redring** product for every job.

For more detailed information about Redring and our products, you can also visit www.redring.co.uk, or call 0844 372 7750.

Redring Pedigree

Redring is part of Glen Dimplex. As a global group, this gives **Redring** exposure to international design trends, technologies and best-practice, which allows us to market our products to increasingly demanding and design conscious customers.

Redring Solutions

Redring provides showering and hot water solutions, through a market leading range of products; from digital and care showering to electric flow boilers.

Showering

At **Redring** we know there's nothing better than a refreshing shower. Our stylish range has been designed to compliment lifestyles.

Water Heating and Water Boiling

When specifying a hot water heater you need to consider the use that the hot water is going to be put to. We have a comprehensive range of water heating products to suit all applications. Designed using the latest technology and built to **Redring's** exacting standards, the range covers both storage and point-of-use.

Washrooms

Our washroom range of products includes hygienic infra-red hand and face dryers and no-touch flush and hand-wash units, which keeps health and safety in focus and helps to reduce the risks of cross-infection between users.



Digimix
Pages 14-19



Selectronic
Pages 26-29,
44-51



SB2
Pages 116-117



Powerstream Professional
Pages 70-73

Solutions in detail

Showers

Designer

If you want to stay ahead in the style stakes the Designer range is for you. With chrome styling, chic designs and the latest features you can't get any better.

Family

When it comes to safe showering for all the family, look no further than our Family range. Smart modern looks, great performance and reassuring safety features make this range the perfect choice for the family bathroom.

Day to Day

For get up and go showering, it's difficult to beat our Day to Day range. Boasting good performance, ergonomic lines and outstanding value, the range offers effective efficient showering.

Care

Our care range has been developed to make showering easier for the elderly, visually impaired and less able.

Water Heating

Electric Flow Boilers

Whatever the application, our range of electric flow boilers provides an efficient, versatile and safe way of heating water, wherever there is mains electricity.

Electric Unvented and Vented Water Storage

The **Redring** LWSS Duplex Stainless Steel water heating cylinders heads-up our wide range of unvented water storage products and provides effective, fast and safe mains-fed hot water around any property. If it's vented water storage that you require, we have units that range from 100 litres down to 5 litres, including remote units that can be installed under the sink.

Instantaneous Water Heating

With economy settings, our Powerstream 3 Phase Plus instantaneous water heaters are ideal for supplying high volumes of water, wherever a 3-phase 415V supply is available - eliminating the need for centrally stored hot water cylinders and saving on electricity usage and space. We also offer a 12kW unit, which is the highest rated single phase heater on the UK market.

Water Boiling

Beverage Water Boilers

Used for making cups of tea, coffee, soup and hot snacks on demand, our wall-mounted and self-filling range of water boilers can be specified for use across both Industrial and Commercial applications.

Washrooms

Hand Washing

Ideal for use in health and food preparation areas, our hand wash units are compact and simple to operate. A Vortex spray outlet is available, which eliminates the need for costly maintenance, due to the build-up of scale in hard water areas.

Hand Drying

Our hand dryers are widely specified and accepted by the National Health Service, approved by the Health and Safety Executive and the Ministry of Defence, for use in commercial and office environments.

Water Management

Autoflush is a compact, unobtrusive, automatic urinal flush controller which maintains hygiene whilst eliminating water wastage.

Redring Online

Find out more about **Redring** by visiting us online at www.redring.co.uk, which contains comprehensive technical and product installation information, downloads, a brochure builder, latest news and contact details.



Technical Services

Our technical services call centre is staffed by a team trained in diagnosing and rectifying potential concerns over the phone. If for any reason they are unable to solve a problem by phone, they will brief an engineer on your behalf prior to a service visit to ensure that, wherever possible, the problem is fixed first time. The team also provides advice on product selection, application, installation and operation.

For further information: Tel: 0844 372 7766 Fax: 0844 372 7767

Customer Training Centre

The **Redring** Customer Centre at our head office in Peterborough showcases many of the products from our range. The centre is available for product introduction and training for distributors, installers and specifiers by arrangement. Training can be combined with live product demonstration and a guided factory tour of our manufacturing and assembly facilities.

Range Contents

Showering

Introduction		Expressions 500S 36
Range Profile in Detail 10		Smart Technology Electric Showers
Product Selector 12		Slimline 620 38
Thermostatic Digital Mixers		White Ultra Slim Electric Showers
Digimix Pumped 14		Active 350S 40
Low Pressure RF Remote Controlled Thermostatic Digital Mixer Shower		White Dual Concentric Control Electric Showers
Digimix 16		Active 320S 42
High Pressure RF Remote Controlled Thermostatic Digital Mixer Shower		White Dual Control Electric Showers
Digimix Accessories 18		Selectronic Premier  44
Electric Showers		State of the Art Thermostatic Electric Showers
Advantage 550C 20		Selectronic & Selectronic Plus 46
Chrome Multi-service Entry Electric Showers		State of the Art Thermostatic Electric Showers
Slimline 650C 22		Selectronic CWP 48
Chrome Ultra Slim Push Button Electric Showers		Thermostatic Shower and Level Access Pump Pack
Expressions 500SC & 500SL 24		Expressions 570 52
Chrome and Silver Smart Technology Electric Showers		White Integral Pumped Electric Showers
Selectronic Premier  26		Electric Shower Accessories 54
State of the Art Thermostatic Electric Showers		
Selectronic Shower Safe 28		Power Showers
Thermostatic Electric Showers		Expressions 520TS & 520M 56
Advantage 550 30		Power Showers
White Multi-service Entry Electric Showers		Thermostatic Mixers
Slimline 650 32		Selectronic Mixer 58
White Ultra Slim Push Button Electric Showers		TMV3 Thermostatic Mixer Shower
Expressions 550S 34		Bar Mixer 60
Smart Technology Electric Showers		Thermostatic Mixer Shower

Range Contents (continued)

Water Heating Systems

Introduction		Immersion Heaters & Controller	
Range Profile in Detail	62	Domestic Immersion Heaters	90
Product Selector	64	Aqualoy and Copper Water Immersion Heaters	
Electric Flow Boilers		Industrial Immersion Heaters	92
Powerstream Ascari	66	Incoloy 825 Industrial Water Immersion Heaters	
Central Heating and Hot Water Flow Boiler			
Powerstream Professional	70	Immersion Heater Controller	94
Central Heating, Underfloor and Hot Water Flow Boilers		Economy 7 Time Controller	
Unvented Water Storage Heaters		Vented Water Storage Heaters	
Aqualoy LWSS Range	74	Flatback Cistern	96
90-300 litre Stainless Steel Unvented Water Storage Heaters		25-100 litre Vented Water Storage Heaters	
Aqualoy MWSS	78	Contour 7000	98
30-75 litre Stainless Steel Unvented Water Storage Heaters		7 litre Slimline Vented Water Storage Heaters	
Aqualoy SWSS TP	80	WS10	100
7-15 litre Stainless Steel Unvented Water Storage Heaters		10 litre Vented Water Storage Heater	
Aqualoy SWSS	82	WS7-EcoT	102
7-15 litre Stainless Steel Unvented Water Storage Heaters		7 litre Vented Water Storage Heaters with 24 hour, 7 day programmable timer	
MW	86	WS7	104
10-15 litre Unvented Water Storage Heaters		7 litre Vented Water Storage Heaters	
EW	88	WS5	106
10-15 litre Unvented Water Storage Heaters		5 litre Vented Water Storage Heater	
Instantaneous Water Heaters			
Powerstream	108		
Unvented Instantaneous Water Heaters			
Powerstream	110		
3 Phase Plus Eco 3-phase Unvented Water Heaters			

Water Boiling Units

Introduction		SB²	116
Range Profile in Detail	113	2.5-4 litre Beverage Water Boilers	
Water Boiling Units		Corvette	118
		1-3.8 litre Wall Kettle	
SB Professional	114		
2.5-25 litre Stainless Steel Beverage Water Boilers			

Washroom Solutions

Introduction		Hand Dryers	
Range Profile in Detail	120	ADP1 Turbo-Airflo	128
Product Selector	122	High Velocity Automatic Hand Dryer	
Hand Washing		AD1 Autodry	130
Autosensor	124	Compact Automatic Hand Dryers	
Touch-free Vortex Spray Hand Wash Unit			
Instant 3 & 7	126	AD10 Autodry	132
Vortex Spray Hand Wash Units		Automatic Hand Dryers	
		AD20, 30 & 50 Autodry	134
		Automatic Hand and Face Dryers	
		Water Management	
		Autoflush	136
		Water Management	

Technical Tables and Approvals

Technical Tables		Approvals	
Technical Tables	138	Approvals and Associations	140
• Pressure Conversion Table			
• Hot Water Recovery Chart			
• Standard Formulae			
• Temperature Conversion Table			
• Physical Constants			
• Required Hot Water Requirements			









Shower

Range Profile in Detail







Thermostatic Digital Mixers

<p>Digimix Pumped</p>  <p>Page 14</p>	<p>Low Pressure RF Remote Controlled Thermostatic Digital Mixer Shower</p> <p>Designer Showering 3 yr GUARANTEE</p>
<p>Digimix</p>  <p>Page 16</p>	<p>High Pressure RF Remote Controlled Thermostatic Digital Mixer Shower</p> <p>Designer Showering 3 yr GUARANTEE</p>

Electric Showers

<p>Advantage 550C</p>  <p>Page 20</p>	<p>Chrome Multi-service Entry Electric Showers</p> <p>Designer Showering 8.5 kW 9.5 kW 2 yr GUARANTEE</p>
<p>Slimline 650C</p>  <p>Page 22</p>	<p>Chrome Ultra Slim Push Button Electric Showers</p> <p>Designer Showering 8.5 kW 9.5 kW 2 yr GUARANTEE</p>
<p>Expressions 500SC & 500SL</p>  <p>Page 24</p>	<p>Chrome and Silver Smart Technology Electric Showers</p> <p>Designer Showering 8.5 kW 9.5 kW 2 yr GUARANTEE</p>
<p>Selectronic Premier</p>  <p>Page 26</p>	<p>State of the Art Thermostatic Electric Showers</p> <p>Family Showering 8.5 kW 9.5 kW 10.8 kW 3 yr GUARANTEE</p>
<p>Selectronic Shower Safe</p>  <p>Page 28</p>	<p>Thermostatic Electric Showers</p> <p>Family Showering 8.5 kW 9.5 kW 10.8 kW 3 yr GUARANTEE</p>
<p>Advantage 550</p>  <p>Page 30</p>	<p>White Multi-service Entry Electric Showers</p> <p>Family Showering 8.5 kW 9.5 kW 2 yr GUARANTEE</p>
<p>Slimline 650</p>  <p>Page 32</p>	<p>White Ultra Slim Push Button Electric Showers</p> <p>Family Showering 8.5 kW 9.5 kW 10.5 kW 2 yr GUARANTEE</p>
<p>Expressions 550S</p>  <p>Page 34</p>	<p>Smart Technology Electric Showers</p> <p>Family Showering 8.5 kW 9.5 kW 2 yr GUARANTEE</p>
<p>Expressions 500S</p>  <p>Page 36</p>	<p>Smart Technology Electric Showers</p> <p>Family Showering 7.2 kW 8.5 kW 9.5 kW 2 yr GUARANTEE</p>



Electric Showers (continued)

<p>Slimline 620</p>  <p>Page 38</p>	<p>White Ultra Slim Electric Showers</p> <p>Day to Day Showering 8.5 kW 9.5 kW 2 yr GUARANTEE</p>
<p>Active 350S</p>  <p>Page 40</p>	<p>White Dual Concentric Control Electric Showers</p> <p>Showering 7.2 kW 8.5 kW 2 yr GUARANTEE</p>
<p>Active 320S</p>  <p>Page 42</p>	<p>White Dual Control Electric Showers</p> <p>Showering 7.2 kW 8.5 kW 2 yr GUARANTEE</p>
<p>Selectronic Premier</p>  <p>Page 44</p>	<p>State of the Art Thermostatic Electric Showers</p> <p>Care Showering 8.5 kW 9.5 kW 10.8 kW 3 yr GUARANTEE</p>
<p>Selectronic & Selectronic Plus</p>  <p>Page 46</p>	<p>State of the Art Thermostatic Electric Showers</p> <p>Showering 8.5 kW 9.5 kW 10.8 kW 3 yr GUARANTEE</p>
<p>Selectronic CWP</p>  <p>Page 48</p>	<p>Thermostatic Shower and Level Access Pump Pack</p> <p>Care Showering 8.5 kW 9.5 kW 3 yr GUARANTEE</p>
<p>Expressions 570</p>  <p>Page 52</p>	<p>White Integral Pumped Electric Showers</p> <p>Showering 8.5 kW 9.5 kW 2 yr GUARANTEE</p>

Thermostatic and Manual Power Showers

<p>Expressions 520TS & 520M</p>  <p>Page 56</p>	<p>Power Showers</p> <p>Showering 2 yr GUARANTEE</p>
--	---

Thermostatic Mixers

<p>Selectronic Mixer</p>  <p>Page 58</p>	<p>TMV3 Thermostatic Mixer Shower</p> <p>Showering 2 yr GUARANTEE</p>
<p>Bar Thermostatic Mixer</p>  <p>Page 60</p>	<p>Thermostatic Mixer Shower</p> <p>Day to Day Showering 2 yr GUARANTEE</p>

Shower Selector

Choosing the right shower is vitally important.

At **Redring**, customer support begins before you even buy! This selector should enable you to make a decision, but if you require assistance, please ring our customer techline on 0844 372 7766 for further information.

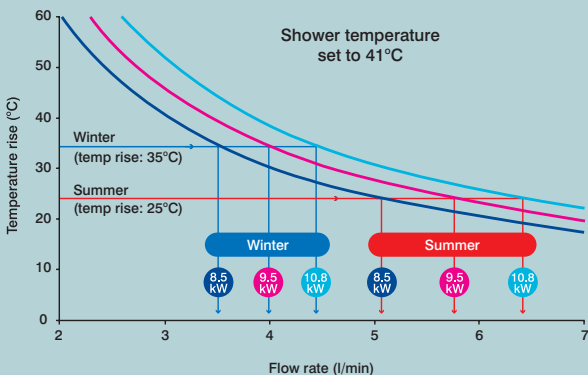
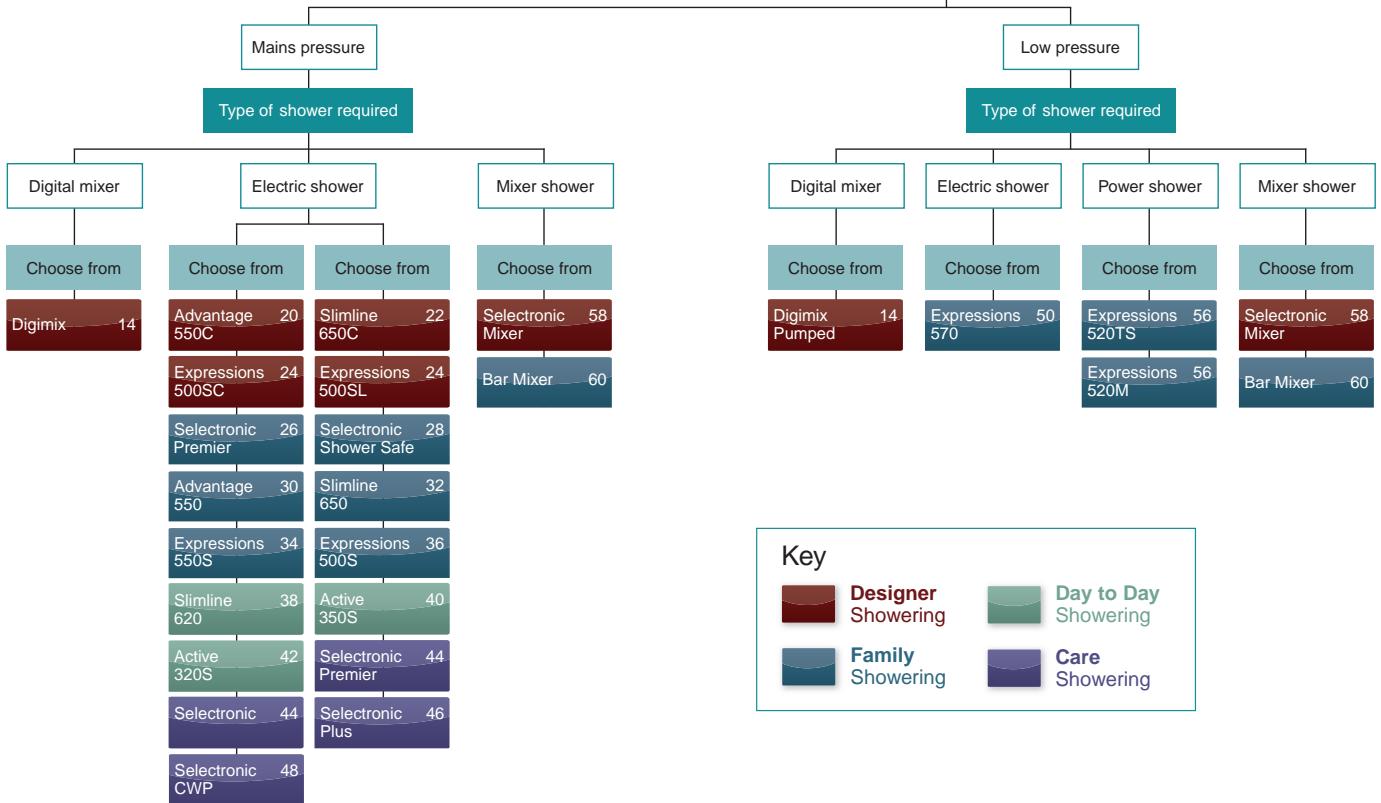

Water flow and temperature graph for instant electric showers

This graph shows the relationship between hot water flow and temperature rise obtainable from an instant electric shower. The different power loadings (available in the range) expressed in kilowatts are shown as curves on the graph. The incoming mains water temperature into your property can vary from 5°C in winter to a maximum of 20°C in summer. The graph shows what can be expected in winter at 5°C and in summer at 15°C. In winter the 8.5kW shower will give a flow rate of about 3.5 litres per minute while in summer it will give approximately 5.1l/min.

Please refer to page 138 for more information.

Digimix Pumped

Low Pressure RF Remote Controlled Thermostatic Digital Mixer Shower

Digimix Pumped brings together the very latest in shower design, styling and performance. Fully thermostatic, this contemporary digital mixer shower provides the ultimate in convenience and control through a remote control which is used to adjust the flow and temperature and incorporates an LCD display. The remote control comes with programmable options that allow you to switch the shower to your preferred setting and prepare the perfect shower before you even set foot into the cubicle.



3 yr GUARANTEE **THERMO** **BEAB Approved** **CE** Portia Accessory Kit shown, see page 20 for further details

Dimensions for Remote Control and Base Unit

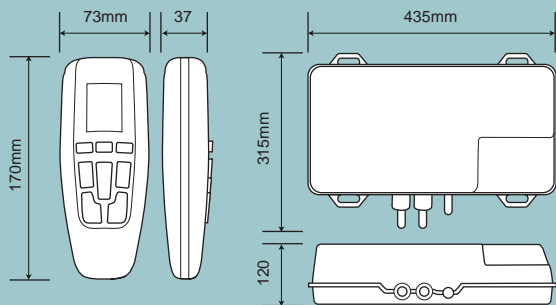

Technical Specification Operating water pressure - 0.15bar min to 1bar max (0.15bar = 1.5m)
 | Water connection - 15mm plain shank tails, push fit or standard compression fittings | RF remote control handset range 10m | Colour coded inlet pipe - red and blue | Anti-vibration mounting on mixer base unit | Mains supply 230/240V | Rating 200W @ 240V | Base supplied with 2m pre-wired cable | Fixing pack supplied | Remote control batteries included - 2 x AAA.

Application Designer showering.

Key Features Suitable for gravity-fed plumbing systems | Remote siting of mixer - ease of installation | Integral pump included for power shower performance | RF remote controlled | LCD digital temperature and flow readout | Programmable pre-set flow and temperature ensures next shower requires no adjustment | Favourite settings programmable | Adjustable automatic off function,

Safety Features Thermostatic | Automatic shutdown if cold or hot water supply fails | Overheat protection | Maintains temperature to + or -1°C (in stable conditions) | Default on/off setting 40°C | Option to limit temperature adjustment | Battery level indicator.

Outer Casing Remote control unit and cradle - High impact | Easy clean | Thermoplastic.

Accessories 4 chrome kits available - See page 18 for details.

Pressure Operating pressure - 0.15bar to 1bar (0.15bar = 1.5m).

Approvals IPX2 Base unit | CE.

Guarantee* 3 year product guarantee (UK).

Product Range

Product Reference	Short Code	Cat. No
Digimix Pumped Digital Mixer	DMP1	46678001

* Terms and conditions apply. Visit www.redring.co.uk for full details.

Digimix

High Pressure RF Remote Controlled Thermostatic Digital Mixer Shower

Digimix brings together the very latest in shower design, styling and performance. Fully thermostatic, this contemporary digital mixer shower provides the ultimate in convenience and control through a remote control which is used to adjust the flow and temperature and incorporates an LCD display. The remote control comes with programmable options that allow you to switch the shower on and prepare the perfect shower before you even set foot into the cubicle.



Portia Accessory Kit shown, see page 20 for further details



Dimensions for Remote Control and Base Unit

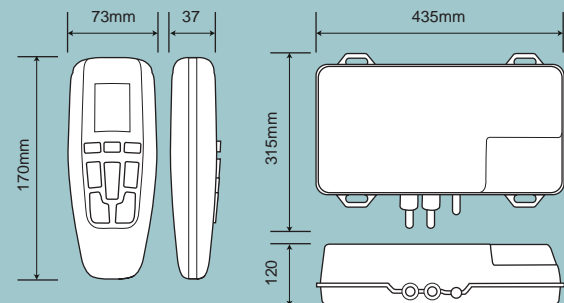

Technical Specification

Operating water pressure - 1bar min to 5bar max. | Water connection - 15mm plain shank tails, push fit or standard compression fittings | RF remote control handset range 10m | Colour coded inlet pipe - red and blue | Anti-vibration mounting on mixer base unit | Mains supply 230/240V | Rating 50W @ 240V | Base supplied with 2m pre-wired cable | Fixing pack supplied | Remote control batteries included - 2 x AAA.

Application

Designer showering.

Key Features

Suitable for most unvented plumbing systems | Remote siting of mixer - ease of installation | RF remote controlled | LCD digital temperature and flow readout | Programmable pre-set flow and temperature ensures next shower requires no adjustment | Favourite settings programmable | Adjustable automatic off function, ensures no waste water.

Safety Features

Thermostatic | Automatic shutdown if cold or hot water supply fails | Overheat protection | Maintains temperature to + or -1°C (in stable conditions) | Default on/off setting 40°C | Option to limit temperature adjustment | Battery level indicator.

Outer Casing

Remote control unit and cradle - High impact | Easy clean | Thermoplastic.

Accessories

4 chrome kits available - See page 18 for details.

Pressure

Operating pressure - 1bar to 5bar.

Approvals

IPX2 Base unit | CE.

Guarantee*

3 year product guarantee (UK).

Product Range

Product Reference	Short Code	Cat. No
Digimix Non-Pumped Digital Mixer	DMNP1	46677001

* Terms and conditions apply. Visit www.redring.co.uk for full details.

Digimix Accessories

The Digimix shower can be combined with one of four stylish accessory kits, each specially selected for stylish design and optimum performance. No matter what your installation requirements or design preferences, we have an accessory set to match your needs.

'Portia' Accessory Kit **Through the wall diverter with dual shower head:** The ultimate showering experience. A stunningly designed accessory set with a diverter control that enables you to switch between an overhead rain shower and a multi-mode handset - perfect for those times you don't want to get your hair wet.

'Cordelia' Accessory Kit **Extendable through the ceiling riser rail and shower head:** A sleek and sophisticated through the ceiling accessory set with a height adjustable multi-mode handset for an invigorating shower.

'Emilia' Accessory Kit **Fixed through the ceiling shower head:** A stylish fixed through the ceiling shower head that provides the perfect rain shower experience.

'Ophelia' Accessory Kit **Bulk-head riser rail and shower head:** A contemporary designed accessory set with a beautifully curved riser rail and multi-mode handset.



Portia

Cordelia

Ophelia

Emilia

Product Range

Product Reference

Portia - Chrome Through-the-Wall Diverter with Dual Shower Head Kit

Cordelia - Chrome Ext. Through-the-Ceiling Riser Rail and Shower Head Kit

Emilia - Chrome Fixed Through-the-Ceiling Shower Head Kit

Ophelia - Chrome Bulk-head Riser Rail and Shower Head Kit

Short Code	Suitable for	Colour	Cat. No
DMACC4	All installations	Chrome	83671104
DMACC3	All installations	Chrome	83671103
DMACC2	All installations	Chrome	83671102
DMACC1	All installations	Chrome	83671101



Dimensions

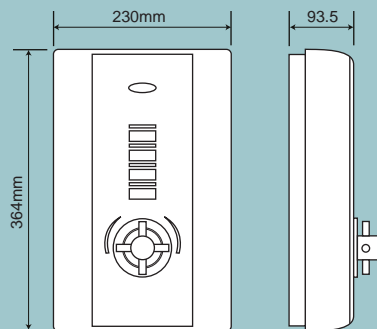

Technical Specification

Left or right - Top, bottom or rear entries | Fittings included | Operating water pressure 0.7-7bar (10-100psi) | Water pressure operated power switch | Water connection - 15mm plain shank tails push fit or standard compression fittings | Removable lower section for ease of installation.

kW variant	kW loading at 230-240V	Recommended cable sizes	Recommended fuse ratings
8.5	7.8 - 8.5	6 - 10mm ²	40 amps
9.5	8.7 - 9.5	6 - 10mm ²	45 amps

Advantage 550C

Chrome Multi-service Entry Electric Showers

Ideal for shower replacement and upgrades, the Advantage 550C has been developed with the very latest instantaneous shower styling, mixing traditional and contemporary functionality. Designed to stabilise temperature changes caused by water pressure fluctuations, it comes with the convenience of a push button start/stop and power selection facility. Phased shutdown is a key feature, and ensures residual hot water is flushed out reducing scale and ensuring cool-start use.

Application Designer showering.

Key Features Six pipe, six cable entry configuration (left, right, top, bottom or rear) - for highly flexible installations or replacements | Push button power selection on/off control | 3 push button power settings (cold/economy/high) | LED power indicator | Independent rotary temperature control for set and forget convenience | Flush buttons for easy clean.

Safety Features Fully temperature stabilised | Smart Time® phased shutdown - electronic flushing of residual hot water which reduces scale and ensures cool-start use | Phased shutdown flashing LED indicator | Overheat protection.

Outer Casing Chrome and black front cover | High impact | Easy clean | Thermoplastic material.

Accessories Chrome 6 mode rub-clean handset and full accessory kit: Soap dish | Hose with retaining ring | Riser rail | Adjustable clamp | See page 54 for further accessories.

Pressure Operating pressure - 0.7bar to 7bar.

Approvals BEAB Approved | CE.

Guarantee* 2 year product guarantee (UK).

Product Range

Product Reference	Short Code	Cat. No
Advantage 550 Chrome 8.5kW	ADV5508C	53674205
Advantage 550 Chrome 9.5kW	ADV5509C	53676705

* Terms and conditions apply. Visit www.redring.co.uk for full details.

8.5
kW9.5
kW2 yr
GUARANTEEBEAB
Approved

Dimensions

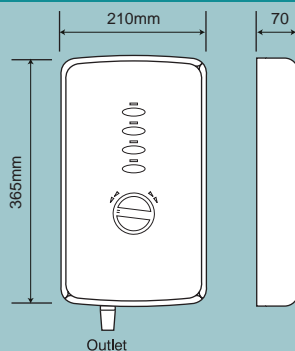

Technical Specification

Operating water pressure 1-10bar (14.5-145psi) | Water pressure operated power switch | Water connection - 15mm plain shank tails push fit or standard compression fittings | Top, bottom or rear cable entry | Top, bottom or rear water entry | Product has a removable side section for ease of installation.

kW variant	kW loading at 230-240V	Recommended cable sizes	Recommended fuse ratings
8.5	7.8 - 8.5	6 - 10mm ²	40 amps
9.5	8.7 - 9.5	6 - 10mm ²	45 amps

Slimline 650C

Chrome Ultra Slim Push Button Electric Showers

The Slimline 650C has a contemporary chrome, ultra slimline profile, generating more space in a shower cubicle. It is fully temperature stabilised and has the added convenience of a push button on/off and power selection facility. The phased shutdown feature ensures that temperatures are managed to deliver a cool and safe start-up for the next user.

Application	Designer showering.
Key Features	Ultra slimline profile Push button power selection and on/off 3 power settings Rotary flow/temperature control for set and forget convenience LED power indication Multi-service points for ease of installation.
Safety Features	Fully temperature stabilised Overheat protection Smart Time [®] phased shutdown - electronic flushing of residual hot water which reduces scale and ensures cool-start use Phased shutdown flashing LED indicator.
Outer Casing	Chrome front cover High impact Easy clean Thermoplastic.
Accessories	Full set of all chrome accessories: Rub-clean, multi-mode handset 6 position variable spray head Soap dish Hose with retaining ring Riser rail Adjustable clamp See page 54 for further accessories.
Pressure	Operating pressure - 1.0bar to 10bar.
Approvals	BEAB Approved CE.
Guarantee*	2 year product guarantee (UK).

Product Range

Product Reference	Short Code	Cat. No
Slimline 650 Chrome 8.5kW	R6508C	53557202
Slimline 650 Chrome 9.5kW	R6509C	53558202

* Terms and conditions apply. Visit www.redring.co.uk for full details.

Expressions 500SC & 500SL

Chrome and Silver Smart Technology Electric Showers

The Expressions 500 Chrome and Silver have been developed with contemporary 'S-line' styling, smart technology and a convenient start/stop button, allowing the power and flow rate setting to remain set ready for your next shower.

Application Designer showering.

Key Features Separate rotary control for power selection | Push-button stop/start, for 'set and forget' convenience | 3 power settings with 'Power On', 'Power Medium' and 'Power High' neon indicators | Top, bottom or rear entry access for cable and cold water supply | Removable corner section for ease of installation.

Safety Features Fully temperature stabilised | Smart Time® phased shutdown - electronic flushing of residual hot water which reduces scale and ensures cool-start use | Rotary flow/temperature control with numerical indicator window | Overheat neon indicator.

Outer Casing Chrome (SC) / Silver (SL) | High impact | Easy clean | Scratch resistant | Thermoplastic.

Accessories Chrome 6 mode rub-clean handset and full accessory kit: Soap dish | Hose with retaining ring | Riser rail | Adjustable clamp | See page 54 for further accessories.

Pressure Operating pressure - 0.7bar to 7bar.

Approvals BEAB Approved | CE.

Guarantee* 2 year product guarantee (UK).

Product Range

Product Reference	Short Code	Cat. No
Expressions 500S Chrome 8.5	EX5008SC	53673005
Expressions 500S Chrome 9.5	EX5009SC	53673505
Expressions 500S Silver 8.5	EX5008SL	53673006
Expressions 500S Silver 9.5	EX5009SL	53673506

* Terms and conditions apply. Visit www.redring.co.uk for full details.



8.5 kW 9.5 kW 2 yr GUARANTEE BEAB Approved CE

Dimensions

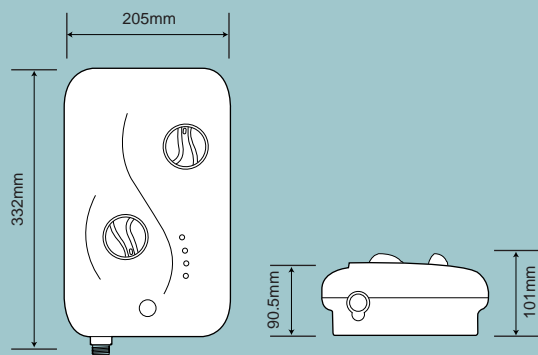

Technical Specification

Operating water pressure 0.7-7bar (10-100psi) | Water pressure operated power switch | Standard 15mm inlet connection | Top, bottom or rear cable entry options | Removable corner section for ease of installation.

kW variant	kW loading at 230-240V	Recommended cable sizes	Recommended fuse ratings
8.5	7.8 - 8.5	6 - 10mm ²	40 amps
9.5	8.7 - 9.5	6 - 10mm ²	45 amps

**NEW
PRODUCT**



Dimensions

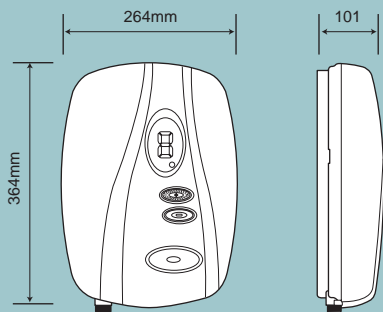

Technical Specification

Operating water pressure 0.7-10bar (10-145psi) | Cable entries: top, bottom and rear (up to 16mm²) | Pipe entries - top, bottom and rear (on right hand side) | Water connection - 15mm inlet connection.

kW variant	kW loading at 230-240V	Recommended cable sizes	Recommended fuse ratings
8.5	7.8 - 8.5	6 - 10mm ²	40 amps
9.5	8.7 - 9.5	6 - 10mm ²	45 amps
10.8	9.9 - 10.8	10 - 16mm ²	45 amps

Selectronic Premier

State of the Art Thermostatic Electric Showers

The Selectronic Premier range of thermostatic showers are the very epitome of control, performance and safety. With unique microprocessor control technology and an array of advanced features, the Selectronic Premier represents the very latest in family showering innovation. Stylish and good looking, the range is available in three different versions, including one with a user friendly wireless remote control.

Application

Family showering.

Key Features

One touch operation | Large tactile, easy to press buttons | Large LED digital readout display | Audible feedback response to commands | Independent temperature adjustment | **Eco Water-Save** feature that automatically calculates and adjusts the optimum flow rates meeting the 'Sustainable Homes' water consumption requirements▲ | **Eco Power-Save** feature that automatically adjusts the power of the shower to achieve the selected water temperatures.

Safety Features

Fully thermostatic operation - maintains temperature within +/- 1°C | Pre-programmed to provide automatic hot water at a constant and safe temperature | Temperature 'Lock Mode', with three optional settings - eliminating any increase by accident▲ | Audible feedback response to commands | Matt antiglare label backing | Phased shutdown - reducing scale and ensuring cool-start for next user | Automatic shutdown after 30 minutes of inactivity.

Outer Casing

White | High impact | Easy clean | Scratch resistant | Thermoplastic | Matt antiglare surface finish to control area.

Accessories

Curved white 6 pattern rub-clean handset | 0.45m riser rail | Adjustable handset holder | Soap dish | 1.25m easy clean smooth shower hose.

Pressure

Operating pressure - 0.7bar to 10bar.

Approvals

BEAB CARE | BEAB Approved | RNIB product endorsement | RNIB Inclusive Design status | Disabled Discrimination Act compliant | WRAS Approved | CE.

Guarantee*

3 year product guarantee (UK).

Product Range

Product Reference	Short Code	Cat. No
Selectronic Standard 8.5kW	SELP85S	53677501
Selectronic Plus 8.5kW	SELP85P	53677505
Selectronic Remote 8.5kW	SELP85PR	53677510
Selectronic Standard 9.5kW	SELP95S	53678501
Selectronic Plus 9.5kW	SELP95P	53678505
Selectronic Remote 9.5kW	SELP95PR	53678510
Selectronic Standard 10.8kW	SELP108S	53679501
Selectronic Plus 10.8kW	SELP108P	53679505
Selectronic Remote 10.8kW	SELP108PR	53679510

* Terms and conditions apply. Selected on installation. Visit www.redring.co.uk for full details.

Selectronic Shower Safe

Thermostatic Electric Showers

The Selectronic Shower Safe range combines unique microprocessor thermostatic controls with contemporary styling to give the ideal shower for all the family. Its simple to use push button controls with premium chrome accessories make it both 'safe' and 'stylish'.

Application Family showering.

Key Features One-touch operation | Tactile button coding with large, easy to press buttons | Heat exchanger designed to minimise the build up of scale | LED digital readout | Independent adjustment for both temperature and water flow rate.

Safety Features Fully thermostatic - adjusting power and water flow to achieve selected temperature | Microprocessor thermostatic control for safety and comfort | Pre-programmed start-up temperature of 41°C | Phased shutdown - reducing scale and ensuring cool-start use | Audible feedback response commands | Auto shut-off to protect against high temperatures.

Outer Casing White | High impact | Easy clean | Scratch resistant | Thermoplastic.

Accessories Premium chrome accessory kit: 6 mode rub clean handset | Riser rail with fully adjustable handset holder | Soap dish | Chrome shower hose | See page 54 for further accessories.

Pressure Operating pressure - 0.7bar to 10bar.

Approvals BEAB Approved | CE.

Guarantee* 3 year product guarantee (UK).



Dimensions

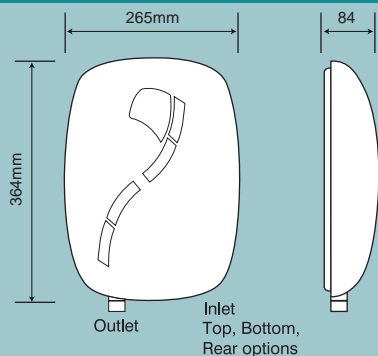

Technical Specification

Operating water pressure 0.7-10bar (10-145psi) | Cable entries: top, bottom and rear (up to 16mm²) | Pipe entries: top, bottom and rear (on right hand side) | Water connection - 15mm plain shank tails push fit or standard compression fitting.

kW variant	kW loading at 230-240V	Recommended cable sizes	Recommended fuse ratings
8.5	7.8 - 8.5	6 - 10mm ²	40 amps
9.5	8.7 - 9.5	6 - 10mm ²	45 amps
10.8	9.9 - 10.8	10 - 16mm ²	45 amps

Product Range

Product Reference	Short Code	Cat. No
Selectronic Safe 8.5kW	SEL85T	53557020
Selectronic Safe 9.5kW	SEL95T	53558020
Selectronic Safe 10.8kW	SEL108T	53559020

* Terms and conditions apply. Visit www.redring.co.uk for full details.

8.5
kW9.5
kW2 yr
GUARANTEEBEAB
APPROVED

Dimensions

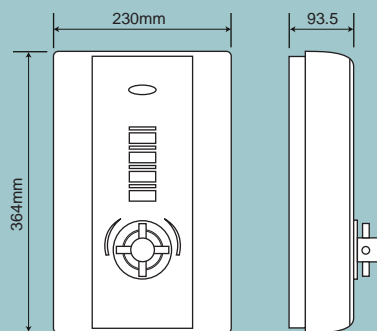

Technical Specification

Left or right - Top, bottom or rear entries | Fittings included | Operating water pressure 0.7-7bar (10-100psi) | Water pressure - operated power switch | Water connection - 15mm plain shank tails push fit or standard compression fittings | Removable lower section for ease of installation.

kW variant	kW loading at 230-240V	Recommended cable sizes	Recommended fuse ratings
8.5	7.8 - 8.5	6 - 10mm ²	40 amps
9.5	8.7 - 9.5	6 - 10mm ²	45 amps

Advantage 550

White Multi-service Entry Electric Showers

Ideal for shower replacement and upgrades, the Advantage 550 has been developed with the very latest instantaneous shower styling, mixing traditional and contemporary functionality. Designed to stabilise temperature changes caused by water pressure fluctuations, it comes with the convenience of a push button start/stop and power selection facility. Phased shutdown is a key feature, and ensures residual hot water is flushed out reducing scale and ensuring cool-start use.

Application Family showering.

Key Features Six pipe, six cable entry configuration (left, right, top, bottom or rear) - for highly flexible installations or replacements | Push button power selection on/off control | 3 push button power settings (cold/economy/high) | LED power indicator | Independent rotary temperature control for set and forget convenience | Flush buttons for easy clean.

Safety Features Fully temperature stabilised | Smart Time® phased shutdown - electronic flushing of residual hot water which reduces scale and ensures cool-start use | Phased shutdown flashing LED indicator overheat protection.

Outer Casing White front cover | High impact | Easy clean | Thermoplastic material.

Accessories Chrome 6 mode rub-clean handset and full accessory kit: Soap dish | Hose with retaining ring | Riser rail | Adjustable clamp | See page 54 for further accessories.

Pressure Operating pressure - 0.7bar to 7bar.

Approvals BEAB Approved | CE.

Guarantee* 2 year product guarantee (UK).

Product Range

Product Reference	Short Code	Cat. No
Advantage 550 8.5kW	ADV5508	53674202
Advantage 550 9.5kW	ADV5509	53676702

* Terms and conditions apply. Visit www.redring.co.uk for full details.

Slimline 650

White Ultra Slim Push Button Electric Showers

The Slimline 650 has an ultra slimline profile, generating more space in a shower cubicle. It is fully temperature stabilised and has the added convenience of a push button power selection facility. The phased shutdown feature ensures that temperatures are managed to deliver a cool and safe start-up for the next user.

Application Family showering.

Key Features Ultra slimline profile | Push button power selection and on/off | 3 power settings | Rotary flow/temperature control for set and forget convenience | LED power indication | Multi-service points for ease of installation.

Safety Features Fully temperature stabilised | Overheat protection | Smart Time® phased shutdown - electronic flushing of residual hot water which reduces scale and ensures cool-start use | Phased shutdown flashing LED indicator.

Outer Casing White | High impact | Easy clean | Scratch resistant | Thermoplastic.

Accessories White and chrome accessory kit: Rub-clean, multi-mode handset with 3 position variable spray head | Soap dish | Hose with retaining ring | Riser rail | Adjustable clamp | See page 54 for further accessories.

Pressure Operating pressure - 1.0bar to 10bar.

Approvals BEAB Approved | CE.

Guarantee* 2 year product guarantee (UK).

8.5 kW 9.5 kW 10.5 kW 2 yr GUARANTEE BEAB Approved CE

Dimensions

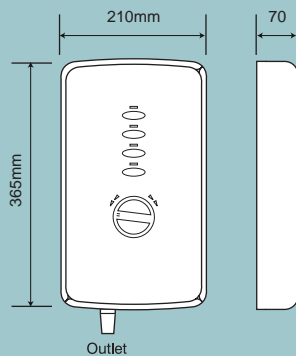

Technical Specification

Operating water pressure 1-10bar (14.5-145psi) | Water pressure operated power switch | Water connection - 15mm plain shank tails push fit or standard compression fittings connection | Top, bottom or rear cable entry | Top, bottom or rear water entry | Accessories - soap dish has removable insert for easy cleaning | Product has a removable side section for ease of installation.

kW variant	kW loading at 230-240V	Recommended cable sizes	Recommended fuse ratings
8.5	7.8 - 8.5	6 - 10mm ²	40 amps
9.5	8.7 - 9.5	6 - 10mm ²	45 amps
10.5	9.6 - 10.5	10 - 16mm ²	45 amps

Product Range

Product Reference	Short Code	Cat. No
Slimline 650 8.5kW	R6508	53557201
Slimline 650 9.5kW	R6509	53558201
Slimline 650 10.5kW	R65010	53559201

* Terms and conditions apply. Visit www.redring.co.uk for full details.

Expressions 550S

Smart Technology Electric Showers

The Expressions 550S has been developed with contemporary 'S-line' styling and smart technology to provide the convenience of a push button start/stop facility and push button power selection. Phased shutdown is a key feature provided through electronic control and this shower also has a temperature ready LED indicator.

Application Family showering.

Key Features Smart Flow® flow indication - LED indicates flow levels | Smart Start® temperature - LED indicates when chosen temperature is ready | Separate push button power controls: 'High On', 'Medium On', 'Cold On' and 'Stop' LED indicators | Removable corner section for ease of installation | Top, bottom or rear entry access for cable and cold water supply.

Safety Features Fully temperature stabilised | Smart Time® phased shutdown - electronic flushing of residual hot water which reduces scale and ensures cool-start use | Phased shutdown flashing LED indicator | Rotary flow/temperature control with Smart Temp® - illuminated digital temperature indicator | Overheat LED indicator.

Outer Casing Polar white | High impact | Thermoplastic | Easy clean.

Accessories Deluxe chrome 6 mode rub-clean handset and oval curved style accessory kit: Soap dish | Hose with retaining ring | Riser rail | Adjustable clamp | See page 54 for further accessories.

Pressure Operating pressure - 0.7bar to 7bar.

Approvals BEAB Approved | CE.

Guarantee* 2 year product guarantee (UK).

8.5 kW 9.5 kW 2 yr GUARANTEE BEAB APPROVED CE

Dimensions

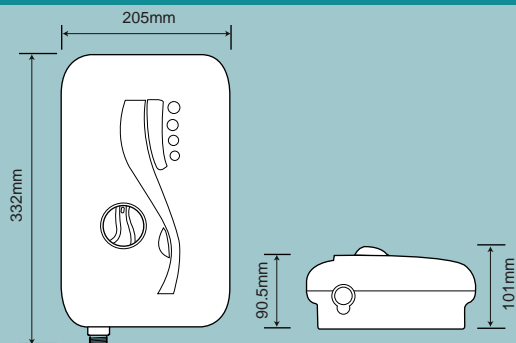

Technical Specification

Operating water pressure 0.7-7bar (10-100psi) | Water pressure operated power switch | Water connection - standard 15mm inlet connection | Top, bottom or rear cable entry options | Fixing pack and instructions supplied | Removable corner section for ease of installation.

kW variant	kW loading at 230-240V	Recommended cable sizes	Recommended fuse ratings
8.5	7.8 - 8.5	6 - 10mm ²	40 amps
9.5	8.7 - 9.5	6 - 10mm ²	45 amps

Product Range

Product Reference	Short Code	Cat. No
Expressions 550S 8.5kW	EX5508S	53674001
Expressions 550S 9.5kW	EX5509S	53674501
Extended Control Lever	LEV2	See page 54

* Terms and conditions apply. Visit www.redring.co.uk for full details.

Expressions 500S

Smart Technology Electric Showers

Developed with contemporary 'S-line' styling, smart technology and a convenient start/stop button, the best selling Expressions 500S allows the power and flow rate setting to remain set ready for your next shower.

Application Family showering.

Key Features Separate rotary control for power selection | Push - button stop/start, for 'set and forget' convenience | 3 power settings with 'Power On', 'Power Medium' and 'Power High' neon indicators | Top, bottom or rear entry access for cable and cold water supply | Removable corner section for ease of installation.

Safety Features Fully temperature stabilised | Smart Time® phased shutdown - electronic flushing of residual hot water which reduces scale and ensures cool-start use | Rotary flow/temperature control with numerical indicator window | Overheat LED indicator.

Outer Casing Polar white | High impact | Easy clean | Scratch resistant | Thermoplastic.

Accessories Chrome 6 mode rub-clean handset and full accessory kit: Soap dish | Hose with retaining ring | Riser rail | Adjustable clamp | See page 54 for further accessories.

Pressure Operating pressure - 0.7bar to 7bar.

Approvals BEAB Approved | CE.

Guarantee* 2 year product guarantee (UK).

Product Range

Product Reference	Short Code	Cat. No
Expressions 500S 7.2kW	EX5007S	53672501
Expressions 500S 8.5kW	EX5008S	53673001
Expressions 500S 9.5kW	EX5009S	53673501
Extended Control Lever	LEV2	See page 54

* Terms and conditions apply. Visit www.redring.co.uk for full details.



Dimensions

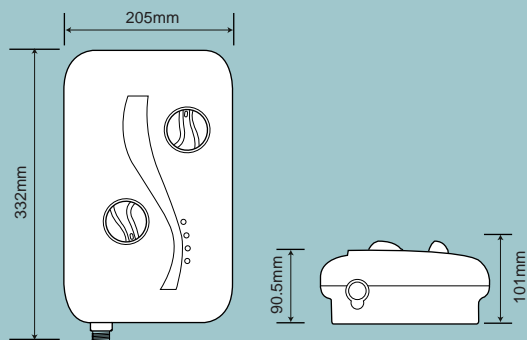

Technical Specification

Operating water pressure 0.7-7bar (10-100psi) | Water pressure operated power switch | Water connection - standard 15mm inlet connection | Top, bottom or rear cable entry options | Removable corner section for ease of installation.

kW variant	kW loading at 230-240V	Recommended cable sizes	Recommended fuse ratings
7.2	6.6 - 7.2	4 - 6mm²	30 amps
8.5	7.8 - 8.5	6 - 10mm²	40 amps
9.5	8.7 - 9.5	6 - 10mm²	45 amps

Slimline 620

White Ultra Slim Electric Showers

Packed full of features, the 620 with its ultra slimline profile, timed phased shutdown, overheat protection and multi-mode handset is an ideal choice for upgrading or replacing existing shower installations to generate more space in a shower cubicle.

- Application** Day to day showering.
- Key Features** Ultra slimline profile | Push button for on/off selection | Rotary power select | Multi-service points for ease of installation | Rotary flow/temperature control | 4 power settings.
- Safety Features** Fully temperature stabilised | Overheat protection | Smart Time® phased shutdown - electronic flushing of residual hot water which reduces scale and ensures cool-start use.
- Outer Casing** Polar white | High impact | Easy clean | Scratch resistant | Thermoplastic.
- Accessories** White accessory kit: Rub-clean, multi-mode handset | 3 position variable spray head | Soap dish | Riser rail | Hose with retaining ring | Adjustable clamp | See page 54 for further accessories.
- Pressure** Operating pressure - 1.0bar to 10bar.
- Approvals** BEAB Approved | CE.
- Guarantee*** 2 year product guarantee (UK).

8.5 kW 9.5 kW 2 yr GUARANTEE BEAB Approved CE

Dimensions

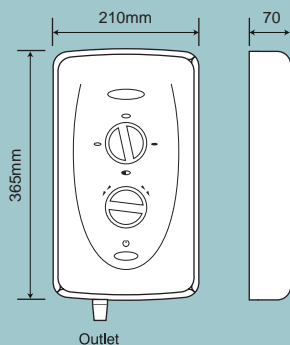

Technical Specification

Operating water pressure 1-10bar (14.5-145psi) | Water pressure operated power switch | Water connection - 15mm plain shank push fit or standard compression fittings | Top, bottom or rear cable entry | Top, bottom or rear water entry | Product has a removable side section for ease of installation.

kW variant	kW loading at 230-240V	Recommended cable sizes	Recommended fuse ratings
8.5	7.8 - 8.5	6 - 10mm ²	40 amps
9.5	8.7 - 9.5	6 - 10mm ²	45 amps

Product Range

Product Reference	Short Code	Cat. No
Slimline 620 8.5kW	R6208	53555201
Slimline 620 9.5kW	R6209	53556201

* Terms and conditions apply. Visit www.redring.co.uk for full details.

7.2
kW8.5
kW2 yr
GUARANTEEBEAB
Approved

Dimensions

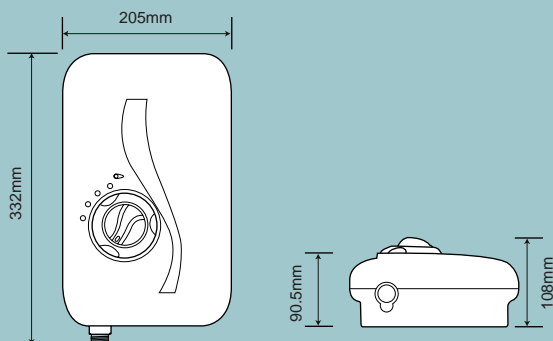

Technical Specification

Operating water pressure 0.7-7bar (10-100psi) | Water pressure operated power switch | Water connection - standard 15mm inlet connection | Top, bottom or rear cable entry options | Removable corner section for ease of installation.

kW variant	kW loading at 230-240V	Recommended cable sizes	Recommended fuse ratings
7.2	6.6 - 7.2	4 - 6mm ²	30 amps
8.5	7.8 - 8.5	6 - 10mm ²	40 amps

Active 350S

White Dual Concentric Control Electric Showers

The Active 350S allows accurate temperature selection. Developed with contemporary 'S-line' styling and smart technology, the integral water control valve provides on/off selection via the outer control knob, allowing the flow rate/temperature position to remain at your favourite setting from your last shower.

Application	Day to day showering.
Key Features	3 power settings Separate controls for temperature adjustment and power selection Neon power indicator.
Safety Features	Fully temperature stabilised Smart Time® phased shutdown - electronic flushing of residual hot water which reduces scale and ensures cool-start use Rotary control for on/off and power selection Overheat protection Electric solenoid operation on/off Temperature and flow control with single turn valve Removable corner section for ease of installation.
Outer Casing	Polar white High impact Easy clean Scratch resistant Thermoplastic.
Accessories	Chrome accessory kit: 3 position variable rub-clean spray head Soap dish Hose retaining ring Riser rail Height adjustable clamp See page 54 for further accessories.
Pressure	Operating pressure - 0.7bar to 7bar.
Approvals	BEAB Approved CE.
Guarantee*	2 year product guarantee (UK).

Product Range

Product Reference	Short Code	Cat. No
Active 350S 7.2kW	A3507S	53671501
Active 350S 8.5kW	A3508S	53672001
Extended Control Lever	LEV3	See page 54

* Terms and conditions apply. Visit www.redring.co.uk for full details.

Active 320S

White Dual Control Electric Showers

The Active 320S has a unique dual control, combining power select and on/off rotary flow/temperature control. Developed with contemporary 'S-line' styling and smart technology this shower comes complete with single mode handset and riser rail all in chrome.

- Application** Day to day showering.
- Key Features** 3 power settings with neon power on indicator | Top, bottom or rear entry access for cable and cold water supply.
- Safety Features** Fully temperature stabilised with 'Smart Stop[®]' hot water purge reducing scale and ensuring cool start | Dual concentric rotary controls for on/off and power selection | Electric solenoid operation on/off | Overheat protection | Temperature and flow control with single turn valve | Removable corner section for ease of installation.
- Outer Casing** Polar white | High impact | Easy clean | Scratch resistant | Thermoplastic.
- Accessories** Chrome accessory kit: Single mode rub-clean handset | Soap dish | Hose retaining ring | Riser rail | Height adjustable clamp | See page 54 for further accessories.
- Pressure** Operating pressure - 0.7bar to 7bar.
- Approvals** BEAB Approved | CE.
- Guarantee*** 2 year product guarantee (UK).



Dimensions

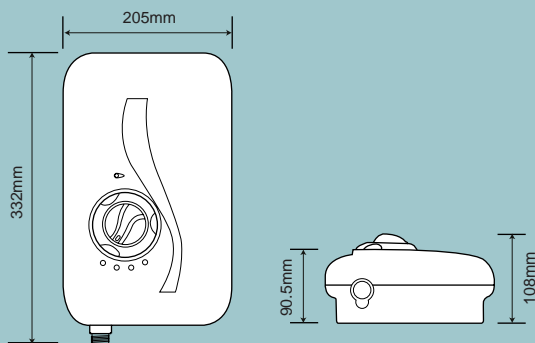

Technical Specification

Operating water pressure 0.7-7bar (10-100psi) | Water pressure operated power switch | Water connection - standard 15mm inlet connection | Top, bottom or rear cable entry options | Removable corner section for ease of installation.

kW variant	kW loading at 230-240V	Recommended cable sizes	Recommended fuse ratings
7.2	6.6 - 7.2	4 - 6mm ²	30 amps
8.5	7.8 - 8.5	6 - 10mm ²	40 amps

Product Range

Product Reference	Short Code	Cat. No
Active 320S 7.2kW	A3207S	53670501
Active 320S 8.5kW	A3208S	53671001
Extended Control Lever	LEV3	See page 54

* Terms and conditions apply. Visit www.redring.co.uk for full details.

**NEW
PRODUCT**



Dimensions

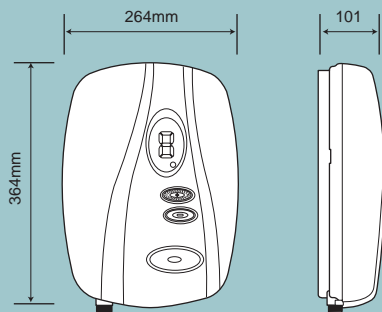

Technical Specification

Operating water pressure 0.7-10bar (10-145psi) | Cable entries: top, bottom and rear (up to 16mm²) | Pipe entries - top, bottom and rear (on right hand side) | Water connection - 15mm inlet connection.

kW variant	kW loading at 230-240V	Recommended cable sizes	Recommended fuse ratings
8.5	7.8 - 8.5	6 - 10mm ²	40 amps
9.5	8.7 - 9.5	6 - 10mm ²	45 amps
10.8	9.9 - 10.8	10 - 16mm ²	45 amps

Selectronic Premier

State of the Art Thermostatic Electric Showers

The Selectronic Premier range of thermostatic showers are the very epitome of control, performance and safety. With unique microprocessor control technology and an array of advanced features, the Selectronic Premier represents the very latest in family showering innovation. Stylish and good looking, the range is available in three different versions, including one with a user friendly wireless remote control.

Application

Care sector showering.

Key Features

One touch operation | Large tactile, easy to press buttons | Large LED digital readout display | Audible feedback response to commands | Independent temperature adjustment | **Eco Water-Save** feature that automatically calculates and adjusts the optimum flow rates meeting the 'Sustainable Homes' water consumption requirements▲ | **Eco Power-Save** feature that automatically adjusts the power of the shower to achieve the selected water temperatures▲.

Safety Features

Fully thermostatic operation - maintains temperature within +/- 1°C | Pre-programmed to provide automatic hot water at a constant and safe temperature | Temperature 'Lock Mode', with three optional settings - eliminating any increase by accident▲ | Matt antiglare label backing | Audible feedback response to commands | Phased shutdown - reducing scale and ensuring cool-start for next user | Automatic shutdown after 30 minutes of inactivity.

Outer Casing

White | High impact | Easy clean | Thermoplastic | Scratch resistant | Matt antiglare surface finish to control area.

Accessories

Curved white 6 pattern rub-clean handset | 0.45m riser rail | Adjustable handset holder | Soap dish | 1.25m easy clean smooth shower hose.

Pressure

Operating pressure - 0.7bar to 10bar.

Approvals

BEAB CARE | BEAB Approved | WRAS Approved | RNIB product endorsement | RNIB Inclusive Design status | Disabled Discrimination Act compliant | CE.

Guarantee*

3 year product guarantee (UK).

Product Range

Product Reference	Short Code	Cat. No
Selectronic Standard 8.5kW	SELP85S	53677501
Selectronic Plus 8.5kW	SELP85P	53677505
Selectronic Remote 8.5kW	SELP85PR	53677510
Selectronic Standard 9.5kW	SELP95S	53678501
Selectronic Plus 9.5kW	SELP95P	53678505
Selectronic Remote 9.5kW	SELP95PR	53678510
Selectronic Standard 10.8kW	SELP108S	53679501
Selectronic Plus 10.8kW	SELP108P	53679505
Selectronic Remote 10.8kW	SELP108PR	53679510

* Terms and conditions apply. Selected on installation. Visit www.redring.co.uk for full details.

Selectronic & Selectronic Plus

State of the Art Thermostatic Electric Showers

Endorsed by the RNIB and selected for Inclusive Design status, these instantaneous showers are the most technologically advanced available from Redring and are the preferred choice of the blind, partially sighted, young children, elderly and less able. Pre-programmed to provide hot water at a comfortable and safe temperature, in lock mode the heat is capped at 40°C, with cooler adjustment; no accidental increase is possible.

Application Care sector showering.

Key Features One-touch operation | Large tactile, easy to press buttons | Independent adjustment for temperature and water flow rate | Large LED digital readout | Automatic shutdown after 30 minutes of inactivity | High-visibility shower head and clamp.

Safety Features Fully thermostatic - adjusting power and water flow to selected temperature | Safety temperature lock 40°C with override | Phased shutdown - reducing scale and ensuring cool-start use | Audible feedback response commands | Matt antiglare label backing.

Outer Casing White | High impact | Easy clean | Scratch resistant | Thermoplastic.

Accessories Curved white 6 pattern rub-clean handset | Soap dish | 0.45m riser rail | Adjustable handset holder | High quality 1.25m chrome shower hose | (Selectronic Plus - as above but with 1m riser rail and 2m smooth white hose).

Pressure Operating pressure - 0.7bar to 10bar.

Approvals BEAB CARE | BEAB Approved | RNIB product endorsement | RNIB Inclusive Design status | Disabled Discrimination Act compliant | WRAS Approved | CE.

Guarantee* 3 year product guarantee (UK).

Product Range

Product Reference	Short Code	Cat. No
Selectronic 8.5kW	SEL85S	53557001
Selectronic 9.5kW	SEL95S	53558001
Selectronic 10.8kW	SEL108S	53559001
Selectronic Plus 8.5kW	SEL85P	53557005
Selectronic Plus 9.5kW	SEL95P	53558005
Selectronic Plus 10.8kW	SEL108P	53559005

* Terms and conditions apply. Visit www.redring.co.uk for full details.



Dimensions

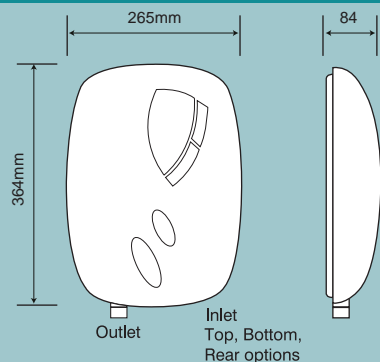

Technical Specification

Operating water pressure 0.7-10bar (10-145psi) | Cable entries: top, bottom and rear (up to 16mm²) | Pipe entries - top, bottom and rear (on right hand side) | Water connection - 15mm plain shank tails, push fit or standard compression fittings | Accessories - soap dish has removable insert for easy cleaning.

kW variant	kW loading at 230-240V	Recommended cable sizes	Recommended fuse ratings
8.5	7.8 - 8.5	6 - 10mm²	40 amps
9.5	8.7 - 9.5	6 - 10mm²	45 amps
10.8	9.9 - 10.8	10 - 16mm²	45 amps

Selectronic Plus complete with Level Access Pump

Thermostatic Shower and Pump Pack

Where a gravity drain is not an option, this shower and pump pack provides a solution. The Selectronic shower controls the level access drain pump directly, removing the need to fit a separate flow switch and associated wiring. Selectronic is endorsed by the RNIB and meets all the latest additional safety standards required for care establishments and less able users.

Application Care sector showering.

Key Features Shower and pump in a pack | Reduced installation time - shower controls pump directly so no requirement for separate flow switch/associated wiring | Meets the Disability Discrimination Act (DDA) | 'Inclusive Design' status, endorsed by RNIB | One-touch operation | Large, tactile, easy to press buttons | Large LED digital readout | Clear print independent adjustment for temperature and water flow rate | Hi-visibility colour coded showerhead & clamp | Automatic shutdown - after 30 minutes of inactivity | Additional time delay adjustment for pump start-up & over-run | Minimal maintenance - diaphragm (not impeller) pump action - removes residual shower waste (hair, grit, gel) without blocking.

Safety Features Thermostatic - adjusting power and water flow to selected temperature | Safety temperature lock 40°C, with override | Phased shutdown - reducing scale and ensuring cool-start use | Audible feedback response commands | Low voltage pump for safe operation | Matt antiglare label backing.

Outer Casing Thermoplastic | High impact | Easy clean | Scratch resistant.

Accessories Multi-mode, rub-clean handset, 1m riser rail | Adjustable handset holder | Soap dish | 2m shower hose

Pressure Operating pressure - 0.7bar to 10bar.

Approvals BEAB CARE | BEAB Approved | RNIB product endorsement | RNIB Inclusive Design status | Disabled Discrimination Act compliant | WRAS Approved | CE.

Guarantee* Shower - 3 year (UK) | Pump - 2 year guarantee (UK).



Dimensions for Shower and Level Access Pump

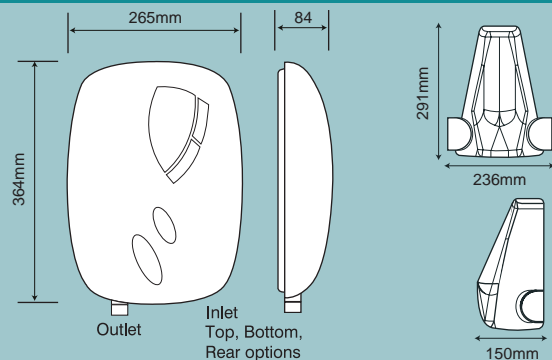

Technical Specification

Operating water pressure 0.7-10bar (10-145psi) | Cable entries: top, bottom and rear (up to 16mm²) | Pipe entries - top, bottom and rear (on right hand side) | Water connection - 15mm plain shank tails push fit or standard compression fittings | Accessories - soap dish has removable insert for easy cleaning.

kW variant	kW loading at 230-240V	Recommended cable sizes	Recommended fuse ratings
8.5	7.8 - 8.5	6 - 10mm ²	40 amps
9.5	8.7 - 9.5	6 - 10mm ²	45 amps

Product Range

Product Reference	Short Code	Cat. No
Selectronic CWP 8.5kW	SEL85LAP	53557090
Selectronic CWP 9.5kW	SEL95LAP	53558090

* Terms and conditions apply. Visit www.redring.co.uk for full details.

Schematic of Typical Installation

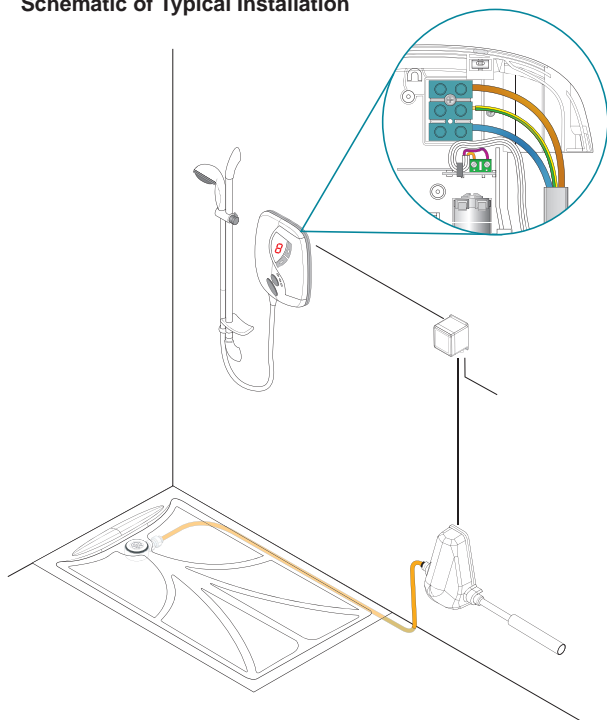

Pump Overview

Combined in harmony with the Selectronic shower, the Level Access Pump uses a diaphragm (not impeller) pump action, and easily removes all residual shower waste including hair, grit and gel - without blocking. With an additional time delay adjustment for start-up and over-run, this level access drain pump allows for the perfect modern wetroom to be installed almost anywhere.

Technical (Cont.d)

NB: The Selectronic shower variant for use with the Selectronic pump system is fully, third party, approved by BEAB to EN 60 335-1: 1995 (Safety of household and similar electrical appliances) and EN 60 335-2-35 (The particular requirements for instantaneous water heaters).

Pack Contents

Thermostatic Shower and Level Access Pump all in one box

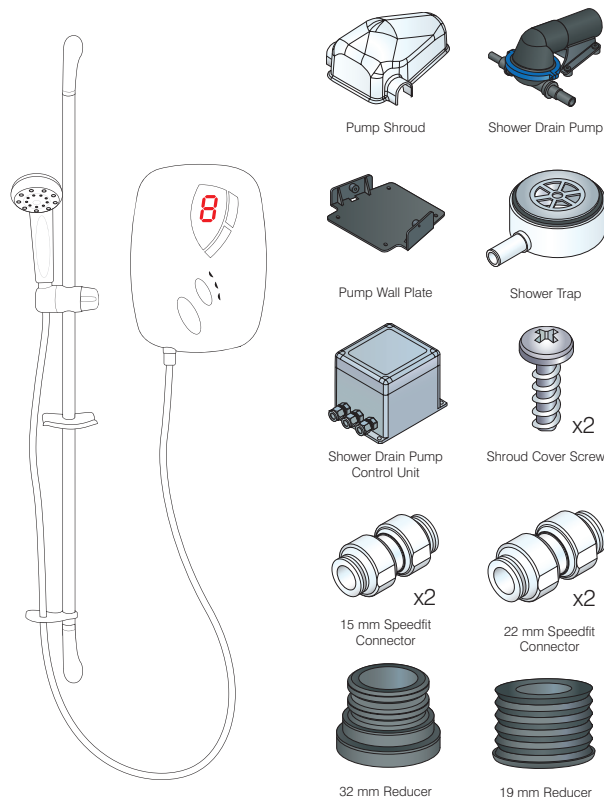

- Selectronic thermostatic shower including 2m hose and 1m riser rail
- Pump shroud
- Shower drain pump
- Pump wall plate
- Shower trap
- Shower drain pump control unit
- Shroud cover screws (x 2)
- 15mm speedfit connectors (x 2)
- 22mm speedfit connectors (x 2)
- 32mm reducer
- 19mm reducer

Expressions 570

White Integral Pumped Electric Showers

The Expressions 570 provides the convenience of electric showering in areas where no mains water, or low water pressure, prevents the use of normal electric instant showers. By combining a standard electric shower and booster pump, this shower can simply be connected to a cold water header tank.

Application Family showering.

Key Features Instant electric shower with integral pump to ensure constant water flow | High and low power selection | Rotary control for temperature/flow selection | Ideal for installations where water pressure is insufficient for an instant shower | Cold water cistern fed (not mains).

Safety Features Power on and overheat neon indicators | Overheat protection.

Outer Casing Polar white | High impact | Easy clean | Scratch resistant | Thermoplastic.

Accessories Full set of white and chrome accessories: Premium wide spray multi-mode handset | Soap dish | Riser rail | Hose with retaining ring | Adjustable clamp | See page 54 for further accessories.

Pressure Cold water cistern fed - operating water pressure: 3" or 0.08m minimum head to 33" or 10m maximum head.

Approvals BEAB Approved | CE.

Guarantee* 2 year product guarantee (UK).



Dimensions and Application

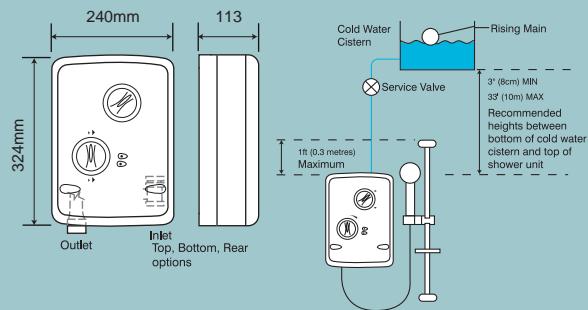

Technical Specification

Cold water cistern fed | Operating water pressure - 3" minimum head to 33" maximum head (0.08m to 10m) | Top, bottom and rear water and cable entry options | 15mm push-fit fitting for cold water inlet connection | The unit incorporates a 240V 140W AC motor to boost flow | Maximum flow rate - 7.0 litres/min | Accessories - soap dish has removable insert for easy cleaning.

kW variant	kW loading at 230-240V	Recommended cable sizes	Recommended fuse ratings
8.5	7.8 - 8.5	6 - 10mm ²	40 amps
9.5	8.7 - 9.5	6 - 10mm ²	45 amps

Product Range

Product Reference	Short Code	Cat. No
Expressions 570 8.5kW	EXP5708	24555515
Expressions 570 9.5kW	EXP5709	24556015

* Terms and conditions apply. Visit www.redring.co.uk for full details.

Electric Shower Accessories

Consistent, all year round shower performance in a range of models to satisfy individual bathroom style requirements. Designed to fit any electric shower, these Accessory Packs contain a shower head, riser rail, brackets, handset holder, soap dish and hose.

Replacement Shower Hoses: 1.25 or 2m hoses | Available in white or chrome - contact our spares department on 0844 372 7750.

Shower Heads: Multi-mode shower head packs to fit any electric shower | Available in white or chrome - contact our spares department on 0844 372 7750.

Standard Accessory Pack: Multi-mode shower head, riser rail, brackets, handset holder, soap dish and hose | Available in white.

Extended Riser: The 1 metre extended length riser rails bring the shower head and soap dish within easy reach of children, the elderly or the less-able and are available in white or chrome, in 18 or 22mm diameter.

Complete Care Pack: For all instant showers to assist less able users. Includes brackets, multi-mode handset, handset clamp, soap dish and hose retainer with 2m hose and 1m riser rail.

Curtain Rail Pack The versatile curtain rail pack is designed to fit virtually any shape of bathroom. Contains a white curtain, curtain rail, corner fittings, curtain clips and full fixing kit. Available with or without a non-slip bath mat.

Ext. Shower Lever Ideal for children or the less-able, this extended Control shower control lever is interchangeable with Expressions 550S and 500S (LEV2) and Active 350S and 320S (LEV3).



Helena

Jessica

Isobella

Maria

Viola

Extended Control Lever

Complete Care Pack

Product Range

Product Reference

Helena - Chrome accessory kit with curved riser and 6 mode handset

Jessica - Chrome accessory kit with straight riser and 6 mode handset

Isobella - Chrome accessory kit with straight riser and 3 mode handset

Maria - Chrome accessory kit with straight riser and single mode handset

Viola - Full white accessory kit with straight riser and 3 mode handset

Complete care pack

Extended control lever

Extended control lever

Grab rail (plastic)

Curtain and rail pack with fixings

Curtain and rail pack with fixings and non-slip bathmat

Extended 1m riser rail

Short Code	Suitable for	Colour	Cat. No
ACCPKE	All installations	Chrome	83595320
ACCPKD	All installations	Chrome	83595319
ACCPKC	All installations	Chrome	83595318
ACCPKB	All installations	Chrome	83595317
ACCPKA	All installations	White	83595321
CCP1	All installations	White	83595322
LEV2	Expressions	White	83595324
LEV3	Active	White	83595325
PGR	All installations	White	83595315
CU1	All installations	White	83792812
CU2	All installations	White	83792811
RAILC2	All installations	Chrome	83595323

Expressions 520TS & 520M Power Showers

The Expressions 520 range delivers luxury showering performance from an integrated booster pump and mixer valve in a simple to plumb installation. Taking both hot and cold water from the cylinder and header tank respectively, the integral pump delivers up to a maximum of 14 litres per minute. The Expressions 520TS unit incorporates fully thermostatic performance.

Application Family showering.

Key Features Electric power shower | On/off flow control | Multi-entry options | Push-fit pipe connections | Separate temperature control.

Safety Features Adjustable temperature limiter with override feature | TS model only: Thermostatic power shower, thermostatic control and operation.

Outer Casing Polar white | High impact | Easy clean | Scratch resistant | Thermoplastic.

Accessories Full set of white and chrome accessories: Premium wide spray multi-mode handset | Soap dish | Hose with retaining ring | Riser rail and adjustable clamp.

Pressure Gravity fed - operating water pressure: 3" or 0.08m minimum head to 33' or 10m maximum head.

Approvals BEAB Approved | CE.

Guarantee* 2 year product guarantee (UK).



Dimensions and Installation

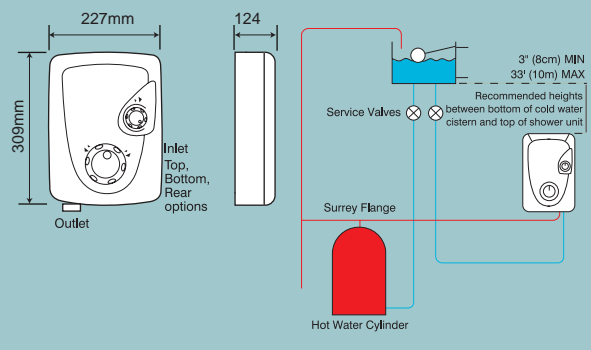

Technical Specification Motor rating - 140 watts @ 240V | Mains supply - 220-240V supply | Top, bottom or rear cable entry | Top, bottom or rear water entry | Accessories - soap dish has removable insert for easy cleaning.

Model variant	Flow rate on full	Mixing chamber	Min. head	Max. head
520M	14 lit/min	Manual Cartridge	3" / 0.08m	33' / 10m
520TS	12 lit/min	Thermostatic Cartridge	3" / 0.08m	33' / 10m

Product Range

Product Reference	Short Code	Cat. No
Expressions 520M	EXM520WC	46598415
Expressions 520TS	EXTS520WC	46599415

* Terms and conditions apply. Visit www.redring.co.uk for full details.

M - Manual | TS - Thermostatic

Selectronic Mixer

TMV3 Thermostatic Mixer Shower

Ideal for retrofit or brand new installations, the Selectronic Mixer, a TMV3 thermostatic shower features sleek design, including a patented 'through the ceiling' water connection - for one of the quickest installation times on the market. Built using the highest quality components this shower fits to just about any plumbing system, on virtually any pressure, with automatic shutdown if the water supply fails.

Application Designer showering.

Key Features Simply connect to water supplies within roof cavity | Includes pre-assembled hot and cold feed pipes plus isolating valves with filters | Surface mounted for minimal bathroom disruption - no channel pipe to cut | No tile or wall cutting required | Quick to install - only two fixings needed | UK design and manufacture - hot and cold water supplied down riser rail | Compatible with just about any plumbing system.

Safety Features Thermostatic | TMV3 certified | Automatic shutdown if cold or hot water supply fails | Safety button override for hotter shower.

Outer Casing All metal construction in chrome plated solid brass, including the fittings, for strength and durability.

Accessories Full set of all chrome accessories: Multi-mode rub-clean handset | 3 position variable spray head | Soap dish | Hose with retaining ring | Riser rail | Adjustable clamp.

Pressure Operating pressure - 0.1bar to 7bar.

Approvals WRAS Approved product | TMV3 scheme certified.

Guarantee* 2 year product guarantee (UK).

Product Range

Product Reference	Short Code	Cat. No
Selectronic TM	SLT1	36598201

* Terms and conditions apply. Visit www.redring.co.uk for full details.



2 yr
GUARANTEE

THERMO

WRAS
APPROVED

Dimensions

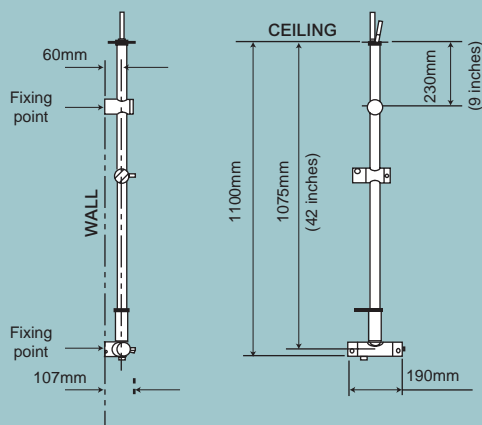

Technical Specification

15mm copper pipes | Suitable for all connections including push-on | Pipes rotate for easy alignment compression and soldered joints | Overall height: 1100mm | Suitable for rooms with ceiling heights of up to 2.5 metres | Pressures from 0.1bar (1 metre head) to 7bar | Maximum hot to cold pressure differential should NOT exceed 2bar at higher pressures or 0.2bar at very low pressures | For pressures in excess of 7bar a pressure regulator should be fitted | Multi-function showerhead for pressures 0.2 - 7bar, single-function showerhead for 0.1 - 7bar especially gravity fed sites.



Dimensions

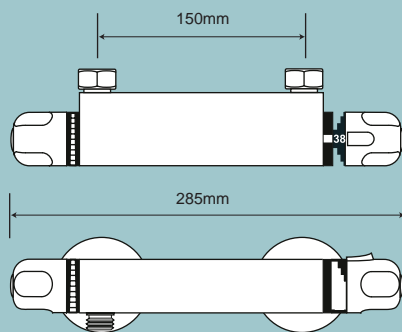

Technical Specification

Will suit: low, mains, pumped, unequal and gravity water pressure systems | Running water pressure 0.1bar to 5.0bar max. | Maximum static water pressure 10bar | Handset height adjustment 530mm (22") Standard 15mm inlet connection.

Bar Thermostatic Mixer

Thermostatic Mixer Shower

The Bar Mixer combines traditional design, contemporary technology and economical pricing and with dual controls, for separate temperature and independent flow adjustment, this thermostatic mixer has built-in temperature safeguards and offers first-rate performance. It recognises and compensates for changes in water pressure and temperature, mixing accordingly, to maintain desired selected shower. It is also easy to install and requires no electrical connections.

- Application** Day to day showering.
- Key Features** Uses COLD water from storage tank and stored HOT water from the cylinder | Easy-grip control increases and decreases flow | Easy-grip independent temperature controls | Adjustable inlet elbows for ease of installation.
- Safety Features** Thermostatic temperature control | Numerical temperature indicator | Maintains temperature to + or -2°C | Temperature limiter factory set at 38°C | Discreet temperature override button facility.
- Outer Casing** Chromed brass.
- Accessories** Chrome multi-mode handset provides 3 different spray options | Crystal clear detachable soap dish for easy cleaning | 1.25m (4ft) flexible hose with retaining ring, riser rail and adjustable clamp.
- Pressure** Operating pressure - 0.1bar to 5.0bar.
- Guarantee*** 2 year product guarantee (UK).

Product Range



Product Reference	Short Code	Cat. No
Bar TM	BTM1	36594240

* Terms and conditions apply. Visit www.redring.co.uk for full details.







Water Heating

Range Profile in Detail

Electric Flow Boilers

Powerstream Ascari  Page 66	Central Heating and Hot Water Flow Boiler	Min. Max. Storage Tank 4 kW 12 kW 3 yr GUARANTEED
	Powerstream Professional  Page 70	Central Heating, Underfloor and Hot Water Flow Boilers







Unvented Water Storage Heaters

Aqualoy LWSS Range  Page 74	90-300 litre Stainless Steel Unvented Water Storage Heaters	Min. Max. Cylinder 3 kW 6 kW 25 yr GUARANTEED
	Aqualoy MWSS  Page 78	30-75 litre Stainless Steel Unvented Water Storage Heaters
Aqualoy SWSS TP  Page 80	7-15 litre Stainless Steel Unvented Water Storage Heaters	Cylinder 3 kW 10 yr GUARANTEED
Aqualoy SWSS  Page 82	7-15 litre Stainless Steel Unvented Water Storage Heaters	Cylinder 3 kW 10 yr GUARANTEED
MW  Page 86	10-15 litre Unvented Water Storage Heaters	3 kW 1 yr GUARANTEED
EW  Page 88	10-15 litre Unvented Water Storage Heaters	3 kW 1 yr GUARANTEED

Immersion Heaters & Controller

Domestic Immersion Heaters  Page 90	Aqualoy and Copper Water Immersion Heaters	Aqualoy Copper 3 kW 3 yr GUARANTEED 1 yr GUARANTEED
	Industrial Immersion Heaters  Page 92	Incoloy 825 Industrial Water Immersion Heaters
Immersion Heater Controller  Page 94	Economy 7 Time Controller	1 yr GUARANTEED

Vented Water Storage Heaters

Flatback Cistern  Page 96	25-100 litre Vented Water Storage Heaters	3 kW 2 yr GUARANTEED
	Contour 7000  Page 98	7 litre Slimline Vented Water Storage Heaters
WS10  Page 100	10 litre Vented Water Storage Heater	2.2 kW 3 yr GUARANTEED
WS7-EcoT  Page 102	7 litre Vented Water Storage Heaters with 24 hour, 7 day programmable timer	3 kW 3 yr GUARANTEED
WS7  Page 104	7 litre Vented Water Storage Heaters	Min. Max. 1 kW 3 kW 3 yr GUARANTEED
WS5  Page 106	5 litre Vented Water Storage Heater	2.2 kW 3 yr GUARANTEED

Unvented Instantaneous Water Heaters

Powerstream  Page 108	Unvented Instantaneous Water Heaters	Min. Max. 9.5 kW 12 kW 3 yr GUARANTEED
	Powerstream 3 Phase Plus  Page 110	Eco 3-phase Unvented Water Heaters

Water Heating Selector

Choosing the right water heating product is vitally important.

At **Redring**, customer support begins before you even buy! This selector should enable you to make a decision, but if you require assistance, please ring our customer techline on 0844 372 7766 for further information.

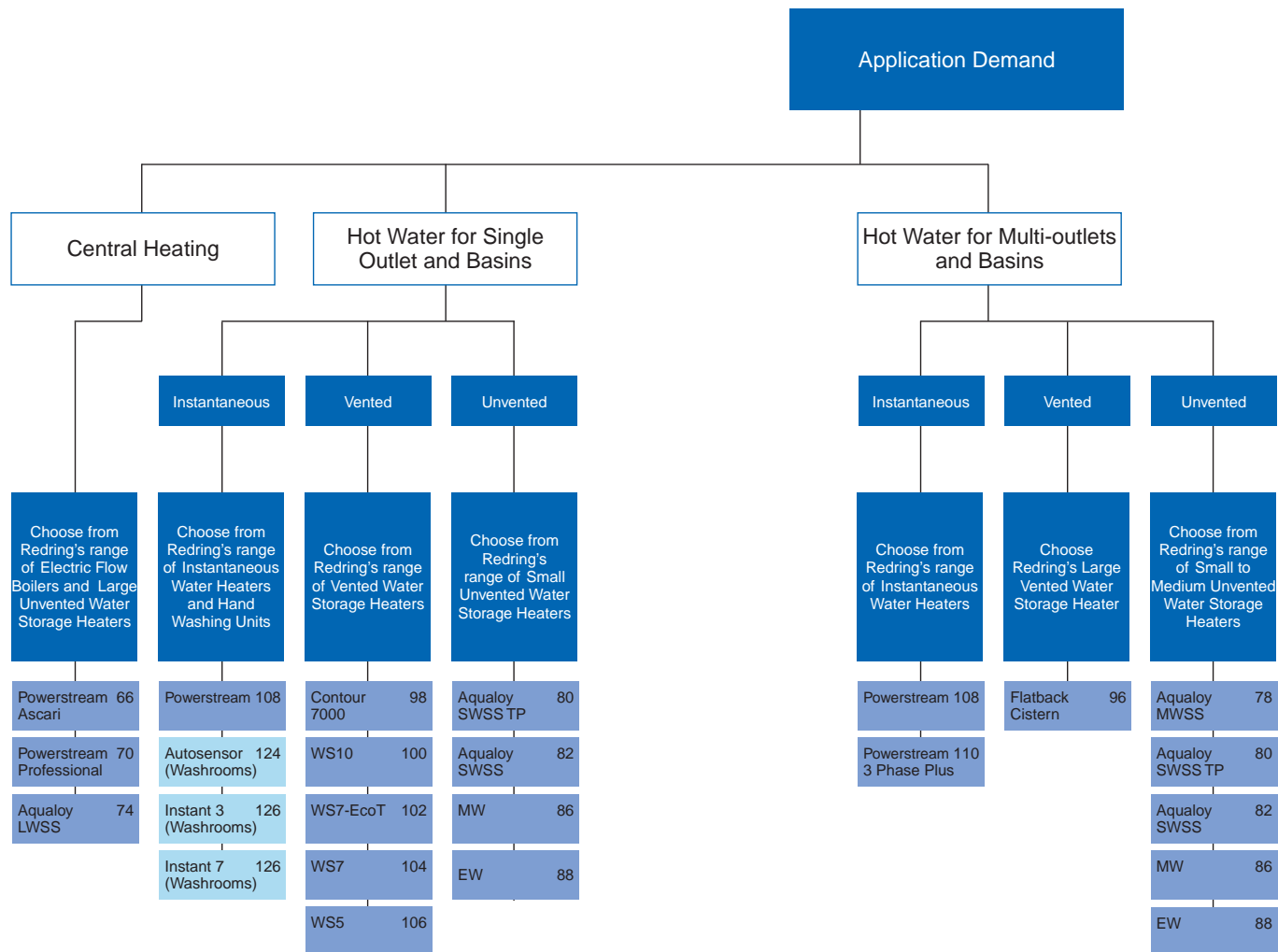



Powerstream Ascari

Central Heating and Hot Water Flow Boiler

This electric boiler is 99% efficient and provides a versatile and safe way of heating water wherever there's mains electricity. Suitable for unvented wet central heating and domestic hot water systems, the Powerstream Ascari electric boiler can be used as a direct replacement for Gas, Oil, Propane, Solid Fuel or Electric Storage heating*. The Powerstream Ascari boiler also provides maximum flexibility as it does not require costly servicing, safety checks or a flue.

Application Central heating and hot water.

Key Features Integral circulation pump and expansion vessel | Auto-adaptability - minimising energy input, smoothes temp. variation of the home and on/off cycling of the boiler | Suitable for sealed and open vented systems, with radiators or underfloor heating | Choice from 12, 8, 6 or 4kW on installation | Compact design - fits into most spaces (including kitchen cupboards) | Low maintenance - no requirement for annual service or safety check (5 year check) | Near silent operation | Selectable heating system water temperature, 21°C - 80°C - allows low energy setting of heating | Cast iron engine for therma stability | Ideal for well insulated properties of up to 80m² | 5 litre water storage, for rapid response.

Safety Features Min/max control adjusts the water temperature output from the boiler | No flue and no fuel tanks give a safe and flexible installation.

Rating 4kW, 6kW, 8kW and 12kW options at installation (230V).

Element Stainless steel.

Outer Casing White steel casing.

Pressure Operating pressure - 0.5bar to 3bar.

Approvals CE.

Guarantee 3 year guarantee on storage tank and 2 years on components (UK).

Product Range

Product Reference	Short Code	Cat. No
Powerstream Ascari	PSA12	45551860

* Building Regulations apply.

Min. Max. Storage Tank Components

4
kW

12
kW

3 yr
GUARANTEE

2 yr
GUARANTEE



Dimensions and Application

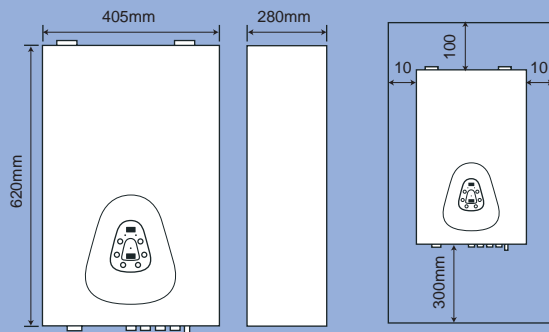

Technical Specification

Maximum power 4-12kW | Includes 8 litre expansion vessel, 3bar pressure relief valve and 3-speed pump for quick easy install | 7 -segment digital displays of temperature and pressure | Graduated power on/off reduces instantaneous loads | Frost protection 5°C minimum system temperature | 5 litre water storage | Pump protection, prevents pump sticking | Stainless steel elements | Operating pressure 0.5bar - 3bar | Top or bottom cable entry | NB: Please see page 72 for further technical details.

Electrical

The Powerstream Ascari should be permanently connected to the electrical supply through a double linked switch with minimum breaking capacity for the loading. All wiring should be installed to conform to the current edition of the IEE Wiring Regulations.

Heating only

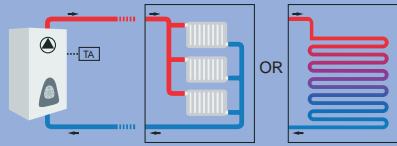

Radiators or floor heating system

Heating and domestic hot water

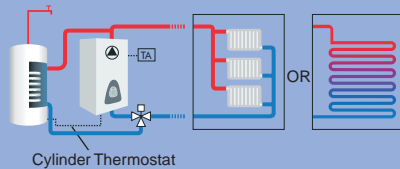

Radiators or floor heating system: the mixing valve is not required

Complementing an alternative energy system

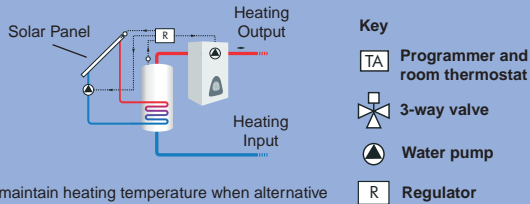

To maintain heating temperature when alternative energy source cannot supply enough heating

Simple to use controls with digital display

- Intelligent operation for comfort and reduced energy use
- System water temperatures can be selected at install or the Ascari can auto-adapt to the requirements of the property, adjusting the water temperature to the optimum setting to reduce energy consumption and smooth the property temperature

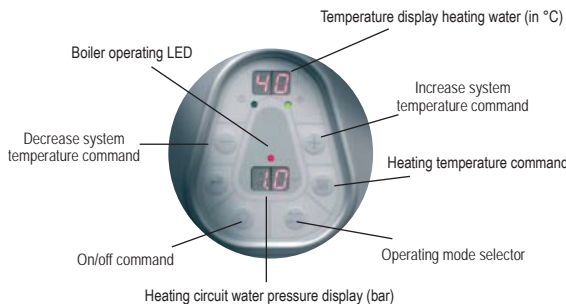

Controls

The Powerstream Ascari boiler has been designed to provide the highest temperature stability and energy consumption possible from an electric boiler. Its 5 litre storage and high thermal mass reduce system cooling, while its electronic temperature and auto-adaptability function keep the room at a stable temperature using the least amount of electrical energy.

The optional outside temperature sensor allows the boiler to quickly adapt to the external temperatures, increasing heat output on cooler days and reducing energy on warmer days, keeping temperature and energy completely under control.

Running Costs

The Powerstream Ascari boiler is fitted with an auto-adaptability function that operates the central heating system according to the heat characteristics of the property, minimising energy consumption and running costs. The Ascari is designed for use with extended hours off-peak tariffs. Please ask your energy supplier for details of optimum tariffs.

Filling Loop

The Powerstream Ascari is not fitted with a filling loop. Any filling loop being fitted should comply with the Water Supply (water fittings) Regulations 1999 Section G24.1 and G24.2. A filling loop should be fitted at some point to allow the CH system to be filled.

Parallel Operation

For larger properties, multiple boilers may be installed in parallel.

Hot Water Storage

Ask for the Redring Aqualoy LWSS 2304 Duplex Stainless Steel water storage heaters that provide effective, fast and safe hot water for baths, showers and other domestic appliances around any property. For use with direct and indirect heating applications the Aqualoy LWSS cylinders are a high quality vessel employing the best in tig welding technology, the LWSS range also features high flow rates and energy efficient insulation.

Powerstream Professional Central Heating, Underfloor and Hot Water Flow Boilers

This electric flow boiler provides a versatile and safe way of heating water, where there's mains electricity. Suitable for vented and unvented wet central heating, underfloor heating and domestic hot water, Powerstream Professional can be used instead of Gas, Oil, Propane, Solid Fuel or Electric Storage heating*. 99% efficient, this boiler is highly flexible as no servicing, safety checks or flue are needed.

Application Central heating, underfloor heating and hot water.

Key Features 7 power options (2kW - 12kW) | Compact design fits in most spaces (including kitchen cupboards) | Solid state technology for long-life | No moving parts, maximum reliability | Minimal service and maintenance costs | Suitable for sealed and open vented systems with radiators or underfloor heating | Uses standard radiators, programmer, pump, room stat and thermostatic radiator valves | Thermostatic range 30°C to 55°C (underfloor) or 55°C to 80°C (central heating).

Safety Features Min/max control adjusts the temperature | No flue and no fuel tanks give a safe and flexible installation.

Rating 2kW, 4kW, 6kW, 7.5kW, 9kW, 10.5kW & 12kW (240V).

Element Copper sheathed.

Outer Casing White stove-enamelled corrosion-resistant steel.

Pressure Operating pressure - 0.5bar to 3bar.

Approvals BEAB Approved | CE.

Guarantee 2 year product guarantee (UK).



Dimensions

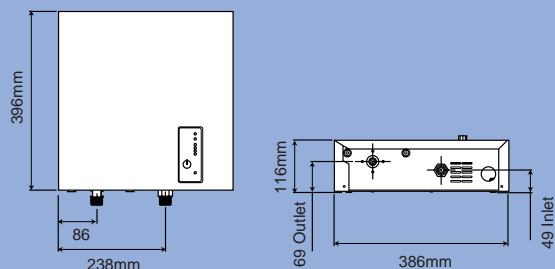

Technical Specification

Thermostatic temperature range 30°C to 55°C (underfloor) or 55°C to 80°C (central heating) | UK manufactured in a BS EN ISO 9001:2000 registered factory | NB: Please see over page for further technical details and sizing guidance.

Boiler variant	Temp. range	BTU output	kW loading @ 230-240V	Cable size guide	Fuse rating guide
RFB2	30 - 80	6830	1.8 - 2	1.5mm ²	13 Amps
RFB4	30 - 80	13660	3.7 - 4	2.5 / 4mm ²	20 Amps
RFB6	30 - 80	20490	5.5 - 6	4mm ²	30 Amps
RFB75	30 - 80	25613	6.9 - 7.5	4 / 6mm ²	35 - 40 Amps
RFB9	30 - 80	30735	8.3 - 9	6 / 10mm ²	40 - 45 Amps
RFB105	30 - 80	35860	9.6 - 10.5	6 / 10mm ²	45 Amps
RFB12	30 - 80	40980	11 - 12	10mm ²	50 Amps

Product Range

Product Reference	Short Code	Cat. No
Powerstream Pro 2kW	RFB2	45670202
Powerstream Pro 4kW	RFB4	45670204
Powerstream Pro 6kW	RFB6	45670206
Powerstream Pro 7.5kW	RFB75	45670207
Powerstream Pro 9kW	RFB9	45670209
Powerstream Pro 10.5kW	RFB105	45670210
Powerstream Pro 12kW	RFB12	45670212

* Building Regulations apply.



Selection Guide (Based on NHBC guidelines¹)

Property Type	Max. floor area (m ² /ft ²)	Space Heating only ²	
		New Build	Older properties
1 room bedsit	20 / 200	RFB2	RFB4
2 room flat	40 / 400	RFB4	RFB6
1 bed house	80 / 800	RFB6	RFB105
2 bed house	100 / 1000	RFB6	RFB12
3 bed house	130 / 1400	RFB9	n/a
4 bed house	150 / 1600	RFB9	n/a
5 bed house	190 / 2000	RFB12	n/a

Property Type	Space Heating & Indirect Hot Water ³			
	Tank (l)	Wash	New Build	Older properties
1 room bedsit	50	1 shower	RFB4	RFB6
2 room flat	115	1 bath	RFB75	RFB9
1 bed house	115	1 bath	RFB9	n/a
2 bed house	115	1 bath	RFB105	n/a
3 bed house	115	1 bath	RFB12	n/a
4 bed house	140	1 bath	RFB12	n/a
5 bed house	200	2 baths	n/a	n/a

NB: ¹ In broad terms, stipulates minimum room temperatures and recovery times for typical hot water draw-offs ² Based on average space heating requirement of 45 W/m² (New Build), 90W/m² (Older properties) ³ Includes requirement for a complete tank full recovery time of less than 3 hours.

Boiler sizing: Please consult your installer/heating engineer/designer as to the correct size of the Powerstream Professional boiler. Size of the property, the insulation properties of the building itself, the local and seasonal weather conditions and exactly what the boiler will be required to heat, eg: heating and/or hot water will need to be considered. To discuss individual delivery and design requirements or for help with making your selection please call: **Technical - 0844 372 7766**

Technical

For Heating only, with Direct domestic hot water cylinder

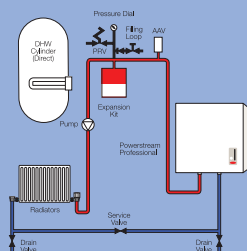

For Underfloor Heating system

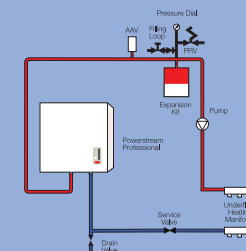

For Heating and domestic hot water & Indirect hot water cylinder

S Plan System

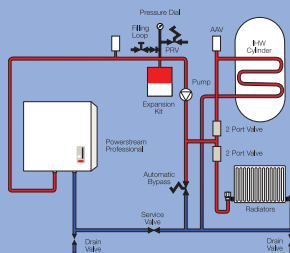

Y Plan System

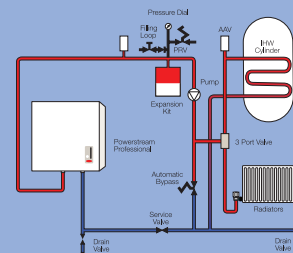

* Expansion kit not required on a vented system

Hot Water Storage

Ask for the Redring Aqualoy LWSS 2304 Duplex Stainless Steel water storage heaters that provide effective, fast and safe hot water for baths, showers and other domestic appliances around any property. For use with direct and indirect heating applications the Aqualoy LWSS cylinders are a high quality vessel employing the best in tig welding technology, the LWSS range also features high flow rates and energy efficient insulation.

NB 1: The Redring Powerstream Professional flow boiler is ideal for providing water to a domestic /light commercial wet central heating system. Where it is intended for use to provide hot water as well, it may be that an alternative direct source of heat is required, eg: immersion heater. This is to ensure compliance with NHBC guidelines and to provide hot water at all times.

NB 2: The Redring Powerstream Professional flow boiler requires fitment of a circulating pump for underfloor and central heating applications. In the case of unvented applications an expansion kit will be required.



Dimensions

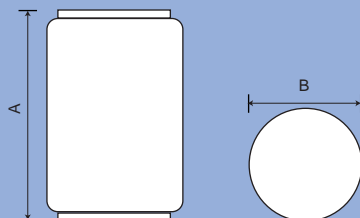

Dimensions (mm)*		
	Min	Max
A	750	1470
B	510	545

* Please see over page for full details of range dimensions.

Technical Specification

Mains water supply essential | Min 1.5bar and a flow rate of 25 litres per minute | Operating pressure - 3bar | Pressure tested to 15bar | Expansion/relief valve set at 5bar | Temperature and relief valve set at 7bar at 90°C | Recommended cable size for all cylinders - 1.5mm² | Electrical connections are located on the front of the unit | Cold water inlet and hot water draw-off - 22mm | Coil flow and return - 22mm | Temperature and pressure relief - 1/2" | Inlet group - 22mm | Tundish inlet - 15mm, outlet - 22mm (both compression) | 200 litre capacities and above are supplied with a secondary return connection | All ancillary components are supplied, allowing for easy, quick and hassle-free installation.

Aqualoy LWSS Range

90-300 litre Stainless Steel Unvented Water Storage Heaters

Water heating cylinders that provide effective and fast, mains-fed, hot water for use with direct and indirect heating applications. Employing the best in tig welding technology, the range features high flow rates and energy efficient insulation.

Application	Hot water storage.
Key Features	Long-life, incoloy, low noise immersion heaters High flow rate, up to 55l/min - ideal to supply power showers without the need for a separate pump Includes expansion vessel.
Safety Features	Pressure tested to 15bar Expansion relief valve set at 5bar Temperature and relief valve set at 7bar at 90°C.
Capacities	90, 125, 150, 170, 200, 250 and 300 litres.
Rating	Immersion heaters 3kW @ 240V (see below).
Outer Casing	Steel, wipe clean, white plastic coated finish and corrosion resistant base and lid.
Insulation	Energy efficient rigid polyurethane foam insulation.
Water Container	Duplex welded stainless shell with pressured domes.
Heat Unit	Long-life Incoloy sheathed element.
Primary Coil	Coil flow and return - 22mm (Indirect only).
Anode	No sacrificial anode required.
Pressure	Operating pressure - 1.5bar to 3.5bar.
Approvals	WRAS Approved Product BEAB Approved CE.
Guarantee	25 year cylinder and 2 year parts guarantee (UK).

Product Range

Product Reference	Cat. No	Capacity (l)	kW loading
LWSS90D	47788101	90	2 x 3
LWSS125D	47788201	125	2 x 3
LWSS150D	47788301	150	2 x 3
LWSS170D	47788401	170	2 x 3
LWSS200D	47788501	200	2 x 3
LWSS250D	47788601	250	2 x 3
LWSS300D	47788701	300	2 x 3
LWSS150i	47788801	150	1 x 3
LWSS200i	47788901	200	1 x 3

Aqualoy LWSS Direct

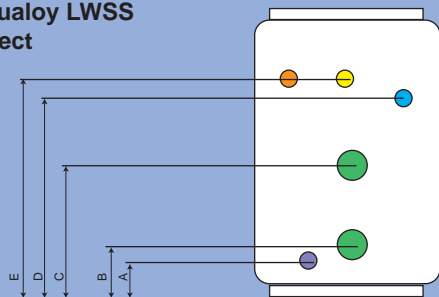

Aqualoy LWSS Indirect

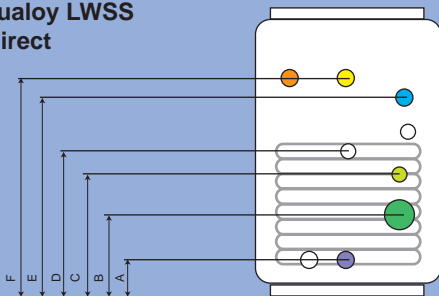

Key

- ½" TPR valve
- 22mm hot water draw-off
- Secondary return
- 1¼" IH boss
- 22mm stat pocket
- 22mm cold feed

Cylinder variant*	Dimensions (mm)		Dimensions (mm)					
	Height	Diameter	A	B	C	D	E	F
LWSS90D	750	510	150	180	400	-	555	-
LWSS125D	935	510	150	180	400	-	760	-
LWSS150D	1060	510	150	180	400	-	885	-
LWSS170D	1200	510	150	180	400	-	1030	-
LWSS200D	1120	545	150	180	400	820	995	-
LWSS250D	1330	545	150	180	400	980	1155	-
LWSS300D	1470	545	150	180	400	1100	1305	-
LWSS150i	1060	510	150	180	380	480	-	885
LWSS200i	1120	545	150	180	330	480	820	995

Cylinder variant*	Capacity (litres)	kW loading @ 240V	Expansion vessel	
			capacity	size (h x d)
LWSS90D	90	2 x 3	8 litres	300 x 200mm
LWSS125D	125	2 x 3	12 litres	255 x 265mm
LWSS150D	150	2 x 3	12 litres	255 x 265mm
LWSS170D	170	2 x 3	18 litres	380 x 265mm
LWSS200D	200	2 x 3	18 litres	380 x 265mm
LWSS250D	250	2 x 3	24 litres	430 x 285mm
LWSS300D	300	2 x 3	24 litres	430 x 285mm
LWSS150i	150	1 x 3	12 litres	255 x 265mm
LWSS200i	200	1 x 3	18 litres	380 x 265mm

* D - Direct, I - Indirect

Domestic Selection Guide

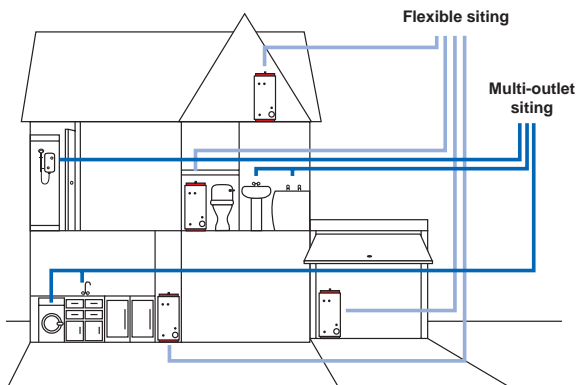

Bedrooms	Hot water demand	Direct	Indirect
2 beds	1 shower	125	n/a
	1 bath, 1 shower	155	n/a
3 beds	1 bath, 1 shower	170	150i
	1 bath, 1 shower	200	n/a
4 beds	2 baths, 1 shower	250	200i
	2 baths, 1 shower	300	n/a
6 beds	2 baths, 2 showers	300	n/a
	3 baths	300	n/a

Siting Options

The structure supporting the heater must be capable of holding the weight of a cylinder when full with water.

Aqualoy LWSS Direct:

Duplex welded Stainless shell with pressured domes | For use with one or two electric immersion heaters (both included with the unit) for direct heating of the stored water | Can be used with peak rate and/or off peak tariff electricity supplies.

Aqualoy LWSS Indirect:

Duplex welded Stainless shell with pressured domes | For use in systems incorporating an indirect heater such as a gas fired boiler or electric flow boiler | Unit also includes one electric immersion heater for direct heating of the stored water.

Re-heat Performance

Requirement	Direct							Indirect	
	90	125	150	170	200	250	300	150	200
Time to re-heat after 70% draw-off	27	37	45	51	63	75	136	26	34
Time to re-heat from cold to 65°C	52	72	86	98	108	144	202	37	33
Weight when full (kg)	125	165	195	220	250	310	360	195	250
24hr heat loss (kWh)	1.1	1.6	1.9	2.1	2.3	2.5	3.1	1.9	2.3

Aqualoy MWSS

30-75 litre Stainless Steel Unvented Water Storage Heaters

Water heating cylinders that provide effective and fast, mains-fed hot water. These medium capacity, wall-mounted, stainless steel storage vessels are suited to medium usage situations, such as commercial sinks or even as prime hot water supply storage.

Application Hot water storage.

Key Features Premium insulation minimises heat loss | Medium capacity for higher water usage | Installation kit | Expansion vessel | Thermostatic control provides water temperature 15°C - 68°C | Wall-mounted | Stainless steel cylinder - 10 year warranty | No anode to service | Direct connection to cold mains water supply | High water flow rates | Incoloy elements.

Safety Features Expansion relief pressure valve set at 6bar | Temperature and pressure relief valve settings - Lift pressure 7bar | Lift temperature - 90°C | Thermal cut-out manual reset.

Capacities 30, 50 and 75 litre.

Rating 3kW @ 230V.

Outer Casing Steel, wipe clean, white plastic coated finish and corrosion resistant base and lid.

Insulation Injected foam - depth 30mm.

Water Container 316L stainless steel.

Heat Unit Long-life Incoloy sheathed elements.

Thermostat Thermostatic temperature control - 15°C-68°C.

Anode No anode to service.

Pressure Operating pressure - 3bar.

Approvals Kiwa Approved Product | CE.

Guarantee 10 year cylinder and 2 year parts guarantee (UK).



Cylinder Parts

3
kW

10 yr
GUARANTEE

2 yr
GUARANTEE



Dimensions

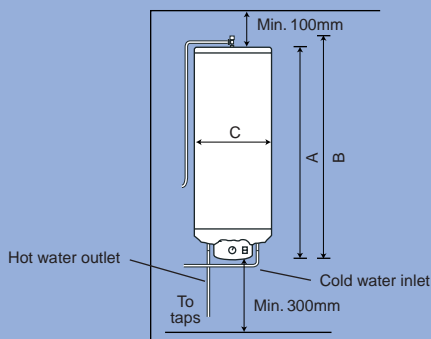

Technical Specification

Heat up time 15°C to 65°C (minutes) - 30L/36, 50L/55, 75L/85 |
Weight when full (kg) - 30L/47, 50L/71, 75L/100 | Electrical supply
230V 50Hz direct connection to 13A fused isolation switch with 3mm
min gap | Expansion vessel 5 litres | 15mm to 22mm Tundish.

Product variant	Dimensions (mm)		
	A Height (excl. T&P valve)	B Total Height	C Width
MWSS30	586	665	400
MWSS50	789	860	400
MWSS75	1093	1175	400

Product Range

Product Reference	Short Code	Cat. No
Aqualoy MWSS 30 litre	MWSS30	47781760
Aqualoy MWSS 50 litre	MWSS50	47781761
Aqualoy MWSS 75 litre	MWSS75	47781762

Aqualoy SWSS TP

7-15 litre Stainless Steel Unvented Water Storage Heaters

Water heating cylinders with temperature and pressure relief valves that provide thermostatically controlled, mains-fed, hot water up to 68°C. These smaller capacity cylinders are ideal for mounting under sinks or near to the point of use.

Application Hot water storage.

Key Features Factory fitted temperature and pressure relief valve | Premium insulation minimises heat loss | Thermostatic control provides water temperature to 15-68°C | Wall mounted | Stainless steel cylinder - 10 year warranty | No anode to service | Direct connection to cold mains | High water flow rates | Ideal for low volume frequent

Safety Features Temperature and pressure relief valve settings - Lift pressure 7bar | Lift temperature - 90°C | Thermal cut-out - 85°C manual reset.

Capacities 7, 10 and 15 litre.

Rating 3kW @ 230V.

Outer Casing Steel, wipe clean, white plastic coated finish and corrosion resistant base and lid.

Insulation Injected foam - depth 30mm.

Water Container 316L stainless steel cylinder.

Heat Unit Incoloy elements.

Thermostat Thermostatic temperature control - 15°C-68°C.

Anode No anode to replace.

Pressure Maximum water supply pressure - 16bar.

Approvals Kiwa Approved Product | CE | BEAB Approved.

Guarantee 10 year cylinder and 2 year parts guarantee (UK).



Cylinder

Parts

3
kW10 yr
GUARANTEE2 yr
GUARANTEEBEAB
Approved

Dimensions

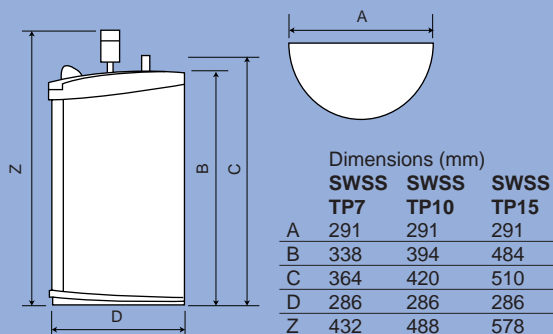

Technical Specification

Heat up time 15°C to 65°C (minutes) - 7L/9, 10L/12 and 15L/18 | Weight when full (kg) - 7L/13.5, 10L/17.2 and 15L/23.3 | Cold feed/hot draw-off connections - 15mm | Minimum recommended mains pressure (performance reduces at lower pressure) - 1.5bar | Maximum working pressure - 6bar | Maximum water supply pressure - 16bar | Expansion relief valve set pressure - 6bar | Temperature & pressure relief valve settings - Lift pressure - 7bar, Lift temperature 90°C | Electrical supply - 230V 50Hz direct connection to 13A fused isolation switch with 3mm min gap | Recommendations are based on BS6700 - Actual water usage varies dramatically per application, the figures given are a guide only. Where water saving devices are used the number of water outlets can be increased.

Installation Kits

See page 84 to determine what installation kit is required with your SWSS TP heater. The installation will not comply with the Water Regulations if the correct kits are not fitted.

Product Range

Product Reference	Short Code	Cat. No
Aqualoy SWSS TP 7 litre	SWSSTP7	47781960
Aqualoy SWSS TP 10 litre	SWSSTP10	47782060
Aqualoy SWSS TP 15 litre	SWSSTP15	47782160
SWSS TP Expansion Kit	SWEXK	87783160
SWSS TP Pressure Reducing Valve	SWPRK	87783161

Aqualoy SWSS

7-15 litre Stainless Steel Unvented Water Storage Heaters

Water heating cylinders that provide thermostatically controlled, mains pressure, hot water up to 68 C. The Aqualoy SWSS cylinders' smaller size allows them to be easily mounted under sinks or any convenient place near to the point of use.

Application Hot water storage.

Key Features High levels of insulation minimise heat loss | Thermostatic temperature control provides water temperature to 15-68°C | Wall-mounted | Stainless steel cylinder with 10 year warranty | No anode to service | High water flow rates | Direct connection to cold mains water supply | Ideal for low volume frequent or irregular use applications | Incoloy elements.

Safety Features Thermal cut-out - manual reset.

Capacities 7, 10 and 15 litre.

Rating 3kW @ 230V.

Outer Casing Steel, wipe clean, white plastic coated finish and corrosion resistant base and lid.

Insulation Injected foam - depth 30mm.

Water Container 316L stainless steel cylinder.

Heat Unit Incoloy elements.

Thermostat Thermostatic temperature control - 15°C-68°C.

Anode No anode to replace.

Pressure Maximum water supply pressure - 16bar.

Approvals Kiwa Approved Product | CE | BEAB Approved.

Guarantee 10 year cylinder and 2 year parts guarantee (UK).



Cylinder

Parts

3
KW10 yr
GUARANTEE2 yr
GUARANTEEBEAB
Approved

Dimensions

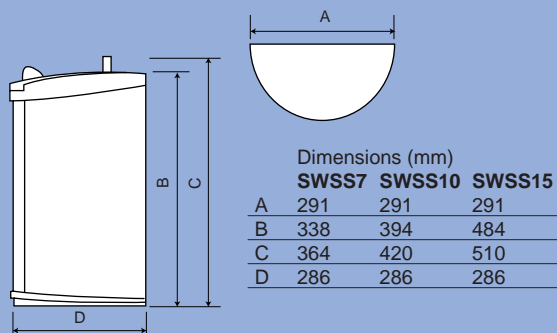

Technical Specification

Heat up time 15°C to 65°C (minutes) - 7L/9, 10L/12 and 15L/18 | Weight when full (kg) - 7L/13.5, 10L/17.2 and 15L/23.3 | Cold feed/hot draw-off connections - 15mm | Minimum recommended mains pressure (performance reduces at lower pressure) - 1.5bar | Maximum working pressure - 6bar | Maximum water supply pressure - 16bar | Expansion relief valve set pressure - 6bar | Electrical supply - 230V 50Hz direct connection to 13A fused isolation switch with 3mm min gap | Recommendations are based on BS6700 - Actual water usage varies dramatically per application, the figures given are a guide only. Where water saving devices are used the number of water outlets can be increased.

Installation Kits

See page 84 to determine what installation kit is required with your SWSS heater. The installation will not comply with the Water Regulations if the correct kits are not fitted.

Product Range

Product Reference	Short Code	Cat. No
Aqualoy SWSS 7 litre	SWSS7	47784562
Aqualoy SWSS 10 litre	SWSS10	47784561
Aqualoy SWSS 15 litre	SWSS15	47784560
SWSS Expansion Kit	SWEXK	87783160
SWSS Pressure Reducing Valve	SWPRK	87783161

Aqualoy SWSS & SWSS TP Installation Kit Guide

Installation kits should be fitted to all SWSS/SWSS TP units of 15 litres or less and in accordance with the details below. The installation will not comply with the Water Regulations if the correct kits are not fitted.

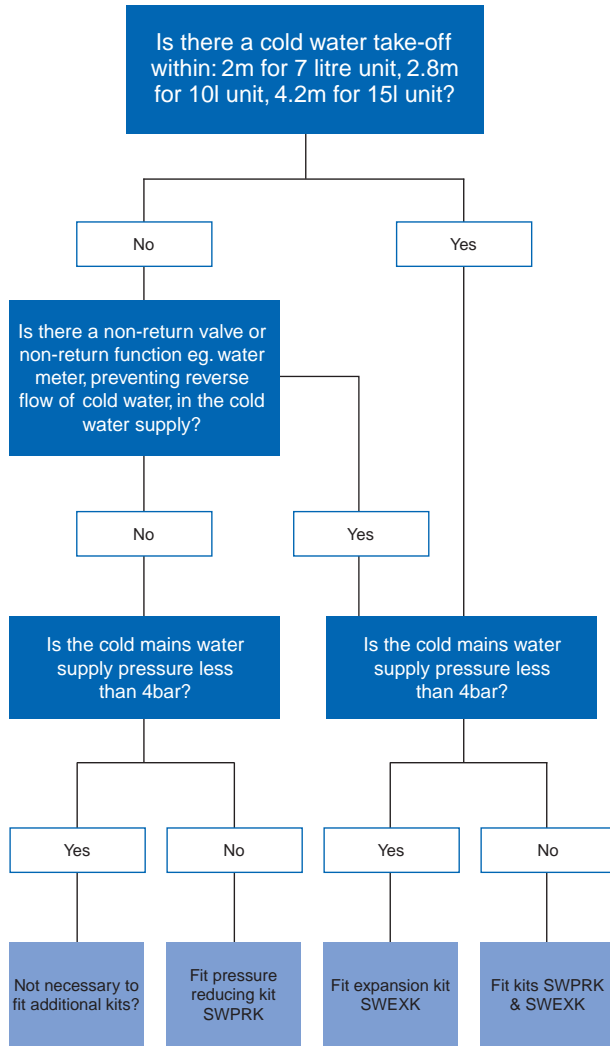

Technical

Expansion back to the mains

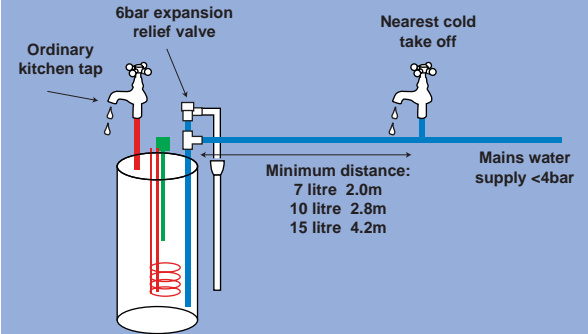

Expansion Kit (SWEXK)

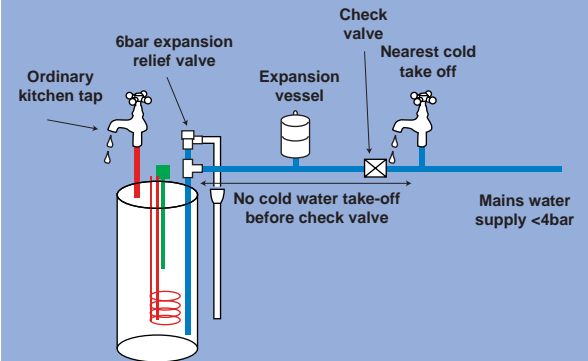

Pressure Reducing Kit (SWPRK)

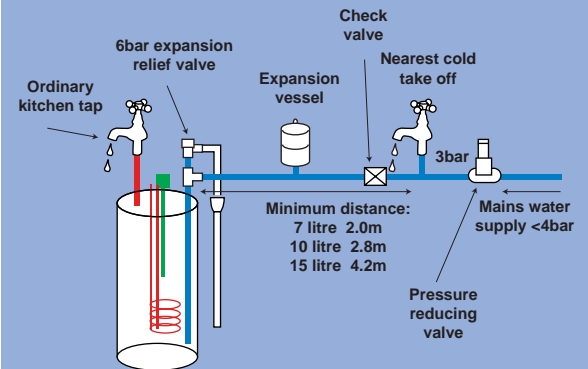

3
kW1 yr
GUARANTEE

WRAS

BEAB
Approved

Dimensions

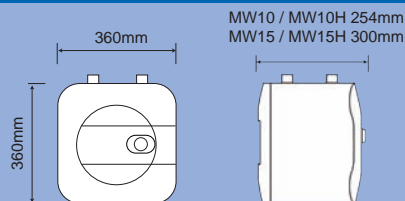

Accessories

Optional Cold Water Pack: A: Expansion vessel (Dia 120mm x H 235mm), B: Pressure reducing valve, C: Check valve | **Additional Accessories:** D: Tundish (supplied as standard with MW) E: Thermostatic blending valve.

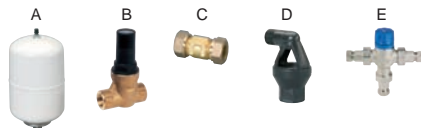

NB: Use with water supply pressures above 6bar or where cold water supply pipe is not long enough to accommodate expansion of hot water, i.e MW15 - Less than 4.5m of 15mm pipe, (MW10 - Less than 3m)

Technical

Operating water pressure 1 - 12bar (above 6bar use cold water pack) | Replaceable magnesium sacrificial anode | Anode available as spare part | Inlet/outlet connections 15mm (½" BSP) | Fixing pack with wall mounting bracket supplied | MW unit needs to discharge to a drain.

Heater variant	Capacity (litres)	kW loading @ 230-240V	Cable size guide	Fuse rating
MW10	10	2.7 - 3	1.5mm ²	13 Amps
MW15	15	2.7 - 3	1.5mm ²	13 Amps
MW10H	10	2.7 - 3	1.5mm ²	13 Amps
MW15H	15	2.7 - 3	1.5mm ²	13 Amps

MW

10-15L Unvented Water Storage Heaters

The MW range has been designed to provide stored hot water from a mains pressurised water supply. MW TP comes complete with a factory fitted temperature and pressure relief device.

Application	Hot water storage.
Key Features	Hot water to up to 4 outlets Balanced supply of hot and cold water Minimal heat loss and energy savings - short pipe runs and superior insulation Water outlet via existing tap or mixer Adjustable thermostat to 70°C Compact for undersink mounting Remote siting possible.
Safety Features	Over-temperature safety cut-out Temperature pressure relief valve Neon light indicates when heater is working.
Capacities	10 and 15 litre.
Rating	3kW @ 240V (2.7kW @ 230V).
Outer Casing	White thermoplastic cover.
Insulation	Foamed polyurethane insulation.
Accessories	See opposite page for details.
Water Container	Vitreous enamelled steel water container.
Heat Unit	Long-life Incoloy elements.
Thermostat	Adjustable thermostat to 70°C.
Anode	Replaceable magnesium sacrificial anode.
Pressure	1 - 12bar (above 6bar use cold water controls pack).
Approvals	WRAS Approved Product BEAB Approved CE.
Guarantee	1 year product guarantee (UK).

Product Range

Product Reference	Short Code	Cat. No
MW10 Undersink	MW10	47782001
MW15 Undersink	MW15	47782101
MW10H Oversink	MW10H	47781001
MW15H Oversink	MW15H	47781101
Optional Cold Water Pack		87783101
Temp. & Pressure Relief Valve		97783258
Thermostatic Blending Valve		87783103

EW

10-15L Unvented Water Storage Heaters

The EW has been designed to provide stored hot water from a mains pressurised water supply, where there's no requirement for a temperature/pressure relief device, making installation simple.

Application	Hot water storage.
Key Features	Hot water to up to four outlets Balanced supply of hot and cold water Heat loss minimisation and energy savings from short pipe runs and superior insulation Water outlet via existing tap or mixer Adjustable thermostat to 70°C Compact shape for undersink mounting Remote siting possible.
Safety Features	Over-temperature safety cut-out 6bar expansion relief valve On/off neon light.
Capacities	10 and 15 litre.
Rating	3kW @ 240V (2.7kW @ 230V).
Outer Casing	White thermoplastic cover.
Insulation	Foamed polyurethane insulation.
Accessories	See opposite page for details.
Water Container	Vitreous enamelled steel water container.
Heat Unit	Long-life Incoloy alloy sheathed elements.
Thermostat	Adjustable thermostat to 70°C.
Anode	Replaceable magnesium sacrificial anode.
Pressure	1 - 12bar (above 6bar use cold water controls pack).
Approvals	BEAB Approved WRAS Approved Product CE.
Guarantee	1 year product guarantee (UK).



Dimensions

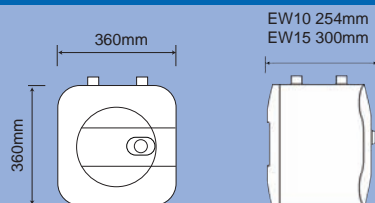

Accessories **Optional Cold Water Pack:** A: Expansion vessel (Dia 120mm x H 235mm), B: Pressure reducing valve, C: Check valve | **Additional Accessories:** D: Tundish, E: Thermostatic blending valve.

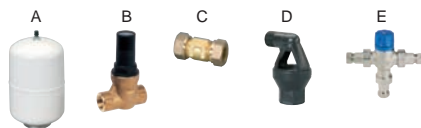

NB: Use with water supply pressures above 6bar or where cold water supply pipe is not long enough to accommodate expansion of hot water, i.e. EW15 - Less than 4.5m of 15mm pipe, (EW10 - Less than 3m)

Technical Operating water pressure 1 - 12bar (above 6bar use cold water pack) | Replaceable magnesium sacrificial anode | Anode available as spare part | Inlet/outlet connections 15mm (1/2" BSP) | Fixing pack with wall mounting bracket supplied | EW unit needs to discharge to a drain.

Heater variant	Capacity (litres)	kW loading @ 230-240V	Cable size guide	Fuse rating guide
EW10	10	2.7 - 3	1.5mm ²	13 Amps
EW15	15	2.7 - 3	1.5mm ²	13 Amps

Product Range

Product Reference	Short Code	Cat. No
EW10 Undersink	EW10	47784501
EW15 Undersink	EW15	47784502
Optional Cold Water Pack		87783101
Tundish		97783236
Temp. & Pressure Relief Valve		97783258
Thermostatic Blending Valve		87783103

Domestic Immersion Heaters

Aqualoy and Copper Water Immersion Heaters

Redring offer a range of dual cut-out immersion heaters to comply with the latest European safety standard, EN 60335-2-73 for fixed immersion heaters. Redring dual cut-out immersion heaters are supplied with a rod thermostat and a separate, 'secondary manual reset safety cut-out'. Dual cut-out immersion heaters are available in standard Copper or Aqualoy variants for use in more aggressive water areas.

Application Hot water heating.

Key Features Comply with European safety standard, EN 60335-2-73 | Available in Aqualoy - for more aggressive water areas | Copper - for use in soft and normal water areas | Dual cut-out heaters supplied complete with rod thermostat

Safety Features Dual cut-out | Separate, 'secondary manual reset safety cut-out', fitted directly to the immersion heater head.

Rating 3kW @ 240V.

Length 11, 14, 27, 30 and 36 inches.

Sheath Copper and Aqualoy.

Thermostat All dual cut-out heaters come with rod thermostats supplied.

Approvals WRAS Approved Product | BEAB Approved | CE.

Guarantee Aqualoy - 3 year | Copper - 1 year guarantee (UK).

Product Range

Product Reference	Short Code	Cat. No	Length
2 1/4" BSP Copper	P11DC	33324501	11"
2 1/4" BSP Copper	P14DC	33324502	14"
2 1/4" BSP Copper	P27DC	33324503	27"
2 1/4" BSP Copper	P30DC	33324504	30"
2 1/4" BSP Copper	P36DC	33324505	36"
2 1/4" BSP Aqualoy	A11DC	33324601	11"
2 1/4" BSP Aqualoy	A27DC	33324602	27"
1 1/4" BSP Unvented Aqualoy	GU11DC	33324701	11"

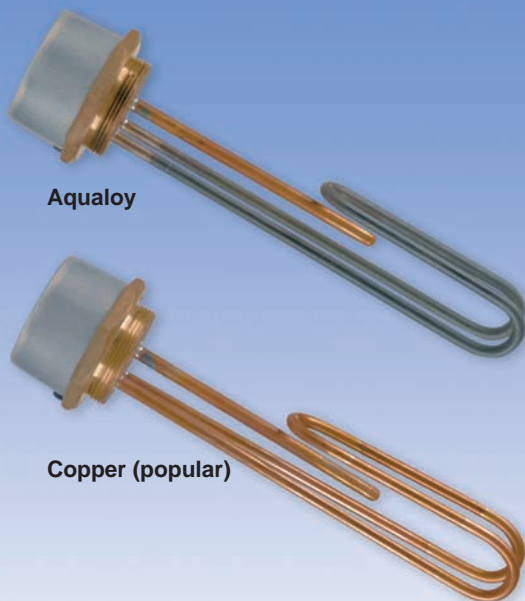

Aqualoy

Copper (popular)

3
KWAqualoy
3 yr
GUARANTEECopper
1 yr
GUARANTEEWRAS
ApprovedBEAB
Approved

Dimensions

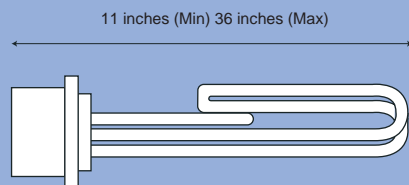

Technical Specification Aqualoy - for use in aggressive water areas | Copper (Popular) - for use in soft and normal water areas.

Redring Dual Thermostats For use with non-dual cut out immersion heaters.

Product Reference	Catalogue No.
7 inch DC rod stat 13A	92301573
11 inch DC rod stat horizontal 13A	92301574
18 inch DC rod stat 13 - 16A	92301575
11 inch DC rod stat vertical 13A	92301580

Industrial Immersion Heaters

Incoloy 825 Industrial Water Immersion Heaters

Redring have a comprehensive range of industrial immersion heaters, using Incoloy sheathed heating elements and adjustable rod thermostats.

Application Hot water heating.

Key Features Loadings available from 2 - 18kW | Wired in single phase or 3 phase | Control thermostat in Incoloy 825 pocket | Incoloy 825 Industrial heaters with angular rotary terminal enclosure - can be moved to any position | Immersed lengths from 11 - 36 inches.

Safety Features Dual cut-out | Separate, 'secondary manual reset safety cut-out', fitted directly to the immersion heater head.

Rating 2, 3, 4, 6, 7.5, 9, 12 and 18kW @ 240V.

Length 11, 14, 16, 24, 27, 30 and 36 inches.

Sheath Incoloy.

Thermostat All dual cut-out heaters come with rod thermostats supplied.

Approvals WRAS Approved Product | CE.

Guarantee 1 year product guarantee (UK).

Product Range

Catalogue Number	Short Code	Loading kW	Phases	Immersed Length
60391301	RY211	2	1 only	11
60391302	RY311	3	1 or 3	11
60391303	RY330	3	1 or 3	30
60391304	RY411	4	1 or 3	11
60391305	RY416	4	1 or 3	16
60391306	RY616	6	1 or 3	16
60391307	RY630	6	1 or 3	30
60391309	RY724	7.5	1 or 3	24
60391310	RY914*	9	1 or 3	14
60391311	RY927	9	1 or 3	27
60391312	RY936	9	1 or 3	36
60391313	RY1224	12	1 or 3	24
60391314	RY1236	12	1 or 3	36
60391315	RY1836	18	1 or 3	36

* Not recommended for aggressive water.



Min.

2
kW

Max.

18
kW

1yr
GUARANTEE

WRAS
APPROVED



Dimensions

11 inches (Min) 36 inches (Max)

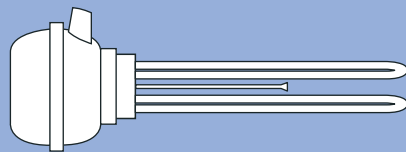

Technical Specification

Industrial heaters - Incoloy 825 sheathed elements 2 1/4" BSP threaded brass heads | Control thermostat in Incoloy 825 pocket | Corrosion resistant polypropylene terminal.

Immersion Heater Controller

Economy 7 Time Controller

The Redring Electronic 7 immersion heater controller allows up to three secure off-peak heating periods every 24 hours to make the maximum use of cheap rate structures - including split tariffs.

Application Hot water storage control.

Key Features One minute accuracy means no accidental running over into full rate tariff periods | Suitable for use with single, dual or two element immersion heaters | Precise and flexible programming - Off peak - up to 3 on/off periods | Pre-programmable automatic boost and one hour manual boost | Illuminated display for easy reading even in a dark cupboard | One touch Winter/Summer change button alters setting and display | 2 year battery reserve protection against power interruption | Easy installation | Microgap on control.

Safety Features Full disconnection to immersion heater(s) on double pole isolator switch.

Rating 230V - 240V, 13A.

Outer Casing Thermoplastic, flame retardant.

Approvals WRAS Approved Product | BEAB Approved | CE.

Guarantee 1 year product guarantee (UK).



Dimensions

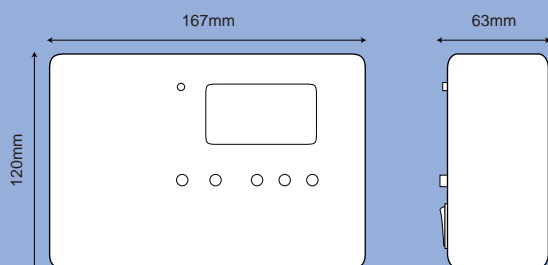

Technical Specification 230V - 240V, 13A | Suitable for immersion heaters up to 3kW | Display: 6.35mm character height, backlit liquid crystal display, am/pm indication, Summer/Winter indication.

Product Variant	Dirt Protection	Moisture Protection	Shock Protection	Max. Op Temp C	Min. Op Temp C
EC7	Normal	Ordinary	Class 1	+35	0

Product Range

Product Ref.	Short Code	Catalogue Number	Supply	Power Consumption	Live Parts
Electronic 7 EC7	82700206	240V AC, 50Hz	10VA max	Yes	

3
KW2 yr
GUARANTEE

WRAS

BEAB
Approved

Dimensions

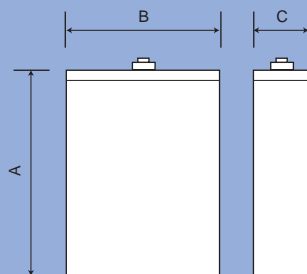

Technical Specification ½" BSP cold water and 22mm compression fitting hot water connections.

Product variant	Dimensions (mm)		
	A Height	B Width	C Depth
CT25	705	470	210
CT50	750	600	320
CT75	925	600	320
CT100	1080	600	320

Flatback Cistern

25-100 litre Vented Water Storage Heaters

Designed for wall-mounted installation and ideal for small commercial kitchens, bathrooms, cloakrooms and canteens, these Flatback Cisterns are compact and provide a multi-outlet water heating solution.

Application	Hot water storage.
Key Features	Choice of 25, 50, 75 or 100 litre capacities 2 adjustable thermostats for precise control Ideal for replacement (overflow and cold feed can be connected on the left or right hand side) 50 to 80°C thermostatic control range Drain connection supplied and fitted Cold water cistern incorporated within the unit.
Safety Features	Overheat protection.
Capacities	25, 50, 75 and 100 litre heaters.
Rating	3kW.
Outer Casing	Corrosion proofed steel, with enamel finish outer casing.
Insulation	High density foam.
Water Container	Copper sheet water vessel with brazed seams.
Heat Unit	Long-life Incoloy sheathed elements.
Thermostat	Fixed 50-80°C thermostatic control range.
Pressure	Operating pressure 0.7bar to 10bar.
Approvals	BEAB Approved WRAS Approved Product CE.
Guarantee	2 year product guarantee (UK).

Product Range

Product Reference	Short Code	Cat. No
Cistern Type 25	CT25	26786401
Cistern Type 50	CT50	26786801
Cistern Type 75	CT75	26786901
Cistern Type 100	CT100	26787001

Contour 7000

7L Slimline Vented Water Storage Heaters

This storage heater has a 7 litre capacity and is ideal for oversink washing. Alternatively, the Contour 7000 Remote allows you to fit under the sink. Featuring an air operated sink mounted switch that, when pressed, delivers hot water through a remote swivel spout at your pre-set temperature.

Application Hot water storage.

Key Features 7 litre capacity, point of use | Adjustable thermostat 15°C - 75°C | Choice of heat settings | Ideal handwash and dishwasher temperature settings indicated on the unit | Complete with 300mm swivel spout | Negligible standing heat loss | Contour 7000 Remote Only - On/off control via touch air switch | Hot water delivered through a remote swivel spout | Remote air switch swivel spout and flexible hose supplied | Neat and out of sight installation.

Safety Features Integral on/off and flow control | Frost protection setting | Tamperproof thermostat cover | Safety over temperature fuse.

Capacities 7 litre.

Rating 1kW and 3kW.

Outer Casing High quality impact resistant ABS cover.

Insulation Polystyrene insulation.

Water Container Corrosion resistant polypropylene.

Heat Unit Sheathed heating elements.

Thermostat Capillary type, externally adjustable - 15°C - 75°C with frost protection setting.

Pressure 0.7bar - 10bar (Flow restrictors included).

Accessories See opposite page for details.

Approvals BEAB Approved | CE.

Guarantee 3 year product guarantee (UK).



Min. Max.

1
kW

3
kW

3 yr
GUARANTEE

BEAB
Approved

CE

Dimensions and Application

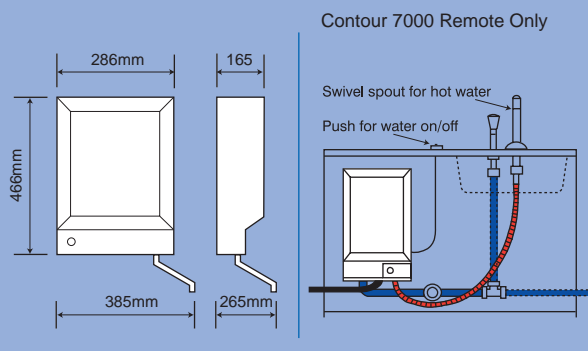

Accessories

A: Extended Swivel Spouts 450mm, **B:** 600mm, **C:** Monoblock Vented Chrome Mixer.



Technical Specification

½" BSP cold water and 22mm compression fitting hot water connections | Restrictors supplied to optimise flow rate | **NB:** We only recommend the use of the Redring Vented Monoblock Mixer.

Product Range

Product Reference	Short Code	Cat. No
Contour 7000 3kW	C73	44784001
Contour 7000 1kW	C71	44784002
Contour 7000 Remote	C7U3	44784020
Extended Swivel Spouts 450mm S1		84780404
Extended Swivel Spouts 600mm S2		84780405
Mono Vented Chrome Mixer	MCM	84780408

2.2
kW3 yr
GUARANTEE

Dimensions and Application

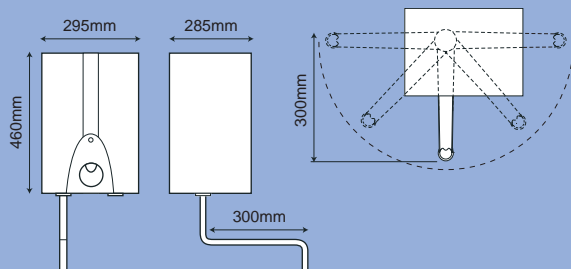

Technical Specification

Electrical - Temperature control, isolation valve | Elements - 2.2kW @ 230V 50Hz | Electrical Connections - 1m 3-core supply cable provided | NB: Open Outlet Device - Outlet must be left open to the atmosphere and should not be modified or restricted in any way.

WS10

10 litre Vented Water Storage Heater

The WS10 provides stored hot water at point of use. It can deliver up to 10 litres of hot water and the open outlet or non-pressurized unit benefits from minimal standing heat loss, because it is installed at point of use.

Application	Hot water storage.
Key Features	10 litre capacity, point of use 4 temperature settings - cold, 38°C, 60°C and 70°C Complete with 300mm swivel spout Negligible standing heat loss Power on indicator.
Safety Features	Auto reset temperature cut-out, allows unit to resume operation in the event of being operated when dry.
Capacities	10 litre.
Rating	2.2kW @ 230V 50Hz.
Outer Casing	White Easy Clean Thermoplastic.
Insulation	Polystyrene insulation.
Water Container	Corrosion resistant polypropylene.
Heat Unit	Sheathed heating elements.
Thermostat	Capillary type, externally adjustable - 15°C - 70°C with frost protection setting.
Pressure	Operating pressure - 0.7bar to 10bar.
Approvals	CE.
Guarantee	3 year product guarantee (UK).

Product Range

Product Reference	Short Code	Cat. No
WS10	WS1022	44780065

**NEW
PRODUCT**



3 kW **3 yr GUARANTEE** **WRAS** **BEAB Approved** **CE**

Programmable timer



Dimensions

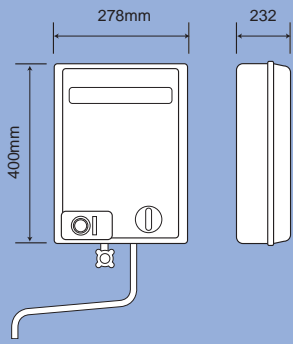

Accessories

A: Extended Swivel Spouts 450mm, **B:** 600mm, **C:** Monoblock Vented Chrome Mixer.



Technical Specification

Cold water 15mm compression | Outlet ½ BSP - swivel spout connection supplied | Restrictors supplied to optimise flow rate | NB: We only recommend the use of the of the Redring Vented Monoblock Mixer.

WS7-EcoT

7 litre Vented Water Storage Heaters with 24 hour, 7 day programmable timer

Building on our best selling WS7 water heater, the EcoT model contains an integral timer that offers the ability to program multiple on-off times throughout the week. This makes it perfect for installations where people are not using the water heater all of the time, as the heater can be programmed to come on only when people need it.

- Application** Hot water storage.
- Key Features** 24 hour, 7 day programmable timer | 7 litre capacity, point of use | 3kW rating | 300mm swivel spout included | Extended outlets available | Wall bracket and full fixing pack supplied | Adjustable thermostat 15°C - 75°C with frost protection setting.
- Safety Features** Frost protection setting | Integral safety over-temperature thermal fuse | Optional tamper proof cover supplied.
- Capacities** 7 litre.
- Rating** 3kW.
- Outer Casing** High quality impact resistant ABS cover.
- Insulation** Polystyrene insulation.
- Water Container** Corrosion resistant polypropylene.
- Heat Unit** Sheathed heating elements.
- Thermostat** Capillary type, externally adjustable - 15°C - 75°C with frost protection setting.
- Pressure** 0.7bar - 10bar (Flow restrictors included).
- Accessories** See opposite page for details.
- Approvals** BEAB Approved | CE.
- Guarantee** 3 year product guarantee (UK).

Product Range

Product Reference	Short Code	Cat. No
WS7 3kW EcoT	WS7-EcoT	44780005
Extended Swivel Spouts 450mm	S1	84780404
Extended Swivel Spouts 600mm	S2	84780405
Mono Vented Chrome Mixer	MCM	84780408



Dimensions

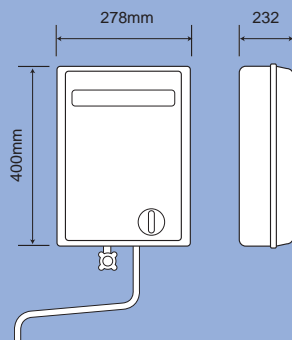

Accessories

A: Extended Swivel Spouts 450mm, **B:** 600mm, **C:** Monoblock Vented Chrome Mixer.



Technical Specification

Cold water 15mm compression | Outlet ½ BSP - swivel spout connection supplied | Restrictors supplied to optimise flow rate | NB: We only recommend the use of the of the Redring Vented Monoblock Mixer.

WS7

7 litre Vented Water Storage Heaters

The WS7 offers an economical solution to provide stored hot water at point of use and can be mounted undersink using the special monoblock chrome-mixer accessory. These units also benefit from minimal standing heat loss, because they are installed at point of use.

Application Hot water storage.

Key Features 7 litre capacity, point of use | Choice of 1kW and 3kW models | 300mm swivel spout included | Extended outlets available | Wall bracket and full fixing pack supplied | Adjustable thermostat 15°C - 75°C with frost protection setting.

Safety Features Frost protection setting | Integral safety over - temperature thermal fuse | Optional tamper proof cover supplied.

Capacities 7 litre.

Rating 1kW and 3kW.

Outer Casing High quality impact resistant ABS cover.

Insulation Polystyrene insulation.

Water Container Corrosion resistant polypropylene.

Heat Unit Sheathed heating elements.

Thermostat Capillary type, externally adjustable - 15°C - 75°C with frost protection setting.

Pressure 0.7bar - 10bar (Flow restrictors included).

Accessories See opposite page for details.

Approvals BEAB Approved | CE.

Guarantee 3 year product guarantee (UK).

Product Range

Product Reference	Short Code	Cat. No
WS7 3kW	WS73	44780001
WS7 1kW	WS71	44780002
Extended Swivel Spouts 450mm	S1	84780404
Extended Swivel Spouts 600mm	S2	84780405
Mono Vented Chrome Mixer	MCM	84780408

2.2
KW3 yr
GUARANTEE

Dimensions and Application

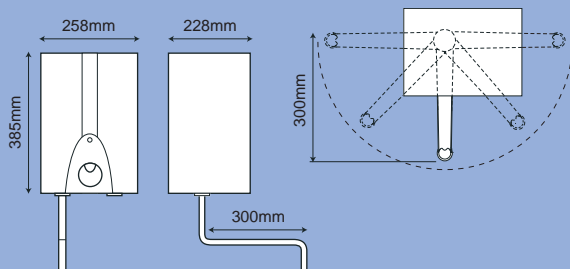

Technical Specification

Electrical - Temperature control, isolation valve | Elements - 2.2kW @ 230V 50Hz | Electrical Connections - 1m 3-core supply cable provided | **NB:** Open Outlet Device - Outlet must be left open to the atmosphere and should not be modified or restricted in any way.

WS5

5 litre Vented Water Storage Heater

The WS5 water heater offers a very economical solution for stored hot water at point of use. It can deliver up to 5 litres of hot water and the open outlet, or non-pressurized unit, benefits from minimal standing heat loss, because it is installed at point of use.

Application	Hot water storage.
Key Features	5 litre capacity, point of use 4 temperature settings - cold, 38°C, 60°C and 70°C Complete with 300mm swivel spout Negligible standing heat loss Power on indicator.
Safety Features	Auto reset temperature cut-out, allows unit to resume operation in the event of being operated when dry.
Capacities	5 litre.
Rating	2.2kW @ 230V 50Hz.
Outer Casing	White Easy Clean Thermoplastic.
Insulation	Polystyrene insulation.
Water Container	Corrosion resistant polypropylene.
Heat Unit	Sheathed heating elements.
Thermostat	Capillary type, externally adjustable - 15°C - 70°C with frost protection setting.
Pressure	Operating pressure - 0.7bar to 10bar.
Approvals	CE.
Guarantee	3 year product guarantee (UK).

Product Range

Product Reference	Short Code	Cat. No
WS5	WS522	44780060



LT1 Basin Tap

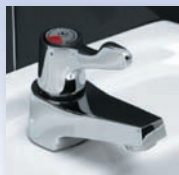

Dimensions and Application

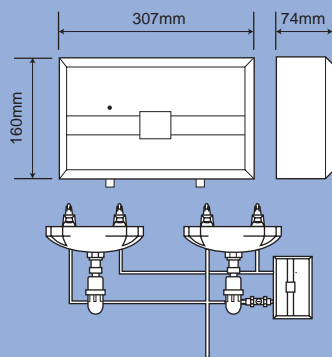

Technical Specification Flow/service valve | Thermal cut-out protection | Unique Redring water flow operated power switch | Corrosion resistant steel backplate | Half power selection available on installation.

Heater variant	Operating pressure	kW loading @ 230-240V	Cable size guide	Fuse rating guide
RP1	15 - 150psi	8.7 - 9.5	6 / 10mm ²	40 Amps
RP10.8	20 - 150psi	9.9 - 10.8	10 / 16mm ²	45 Amps
RP12	25 - 150psi	11 - 12	10 / 16mm ²	50 Amps

Heater variant	Flow rate performance (Winter / Summer)		
	4 litres / min	5 litres / min	6 litres / min
RP1	39 / 54°C	32 / 47°C	28 / 42°C
RP10.8	44 / 58°C	36 / 51°C	31 / 46°C
RP12	48 / 63°C	39 / 54°C	34 / 49°C

Powerstream

Unvented Instantaneous Water Heaters

Powerstream delivers instant hot water at point of use. This compact and unique design eliminates the need for centrally stored hot water cylinders saving on electricity usage and important space.

Application	Instantaneous water heating.
Key Features	12kW unit is the highest rated single phase heater on the UK market Water supplied to one or two outlets (either one shower and one hand basin or two hand basins) Water outlet via spray tap accessories Direct mains supply Small compact shape Remote fitting option No standing heat losses Fast response Half power selection available on installation Corrosion resistant steel backplate.
Safety Features	Thermal cut-out protection Water flow operated power switch.
Rating	9.5, 10.8 and 12kW @ 240V.
Element	Sheathed heating elements.
Outer Casing	Impact resistant thermoplastic cover .
Pressure	Rated pressure - 1bar to 10bar.
Accessories	¼ turn lever control spray tap NB: We only recommend the use of the Redring ¼ Turn Spray Tap.
Approvals	BEAB Approved CE.
Guarantee	3 year product guarantee (UK).

Product Range

Product Reference	Short Code	Cat. No
Powerstream 9.5	RP1	45793201
Powerstream 10.8	RP10.8	45793204
Powerstream 12	RP12	45793202
Shower Mixer Kit	RM1	85793620
¼ Turn Lever Control Spray Taps*	LT1	85793616

(* supplied as pair)



Powerstream 3 Phase Plus Eco 3-phase Unvented Water Heaters

With economy settings the Powerstream 3 Phase Plus instantaneous water heater is ideal for supplying high volumes of water where a 3-phase 415V supply is available.

Application Instantaneous water heating.

Key Features Unit is economical to run, providing flow rates of 6.8-13 litres/min | Two heat settings 38°C or 50°C (at supply temperatures of 12°C) | Rated pressure 10bar allows unit to be connected directly to the cold mains water supply and can be controlled by a normal UK tap fitting | Unique Clickfix® allows the unit to be installed within minutes | Scale resistant design open wound wire elements | Variable depth mounting screws for mounting onto uneven surfaces.

Safety Features Flow activated switch | Over-temperature safety cut-out.

Rating 18kW, 21kW and 24kW (415V 3-Phase).

Element Open wound wire elements.

Outer Casing White impact resistant plastic.

Special Accessories P3P 02RBS Pipe set: When using the instantaneous water heater as a built-under appliance | Priority switch (load reducing relay): For operation with the priority circuit | P3P 02AP Mounting set: For surface-mount installation.

Pressure Rated pressure - 10bar.

Approvals CE.

Guarantee 3 year guarantee on storage tank and 1 year on components (UK).

Min. Max. Storage Tank Components

18
kW

24
kW

3 yr
GUARANTEE

1 yr
GUARANTEE



Dimensions

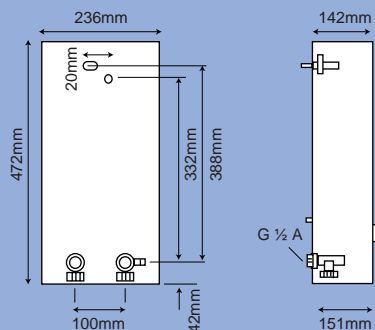

Technical Specification

Electrical supply: 380-415V 3 phase | The unit must be connected to an all-pole isolation switch with a minimum gap of 3mm | Water supply and fittings - supplied from cold mains water supply only - max 20°C | Standard UK water fittings may be connected to the outlet providing they exceed the minimum flow rates | Specific electrical resistance at 15°C $\geq 1300 \Omega \text{cm}$ | See page 112 for further technical details.

Product Range



Product Reference	Short Code	Cat. No
Powerstream 3 Phase Plus 18kW	P3PPE1803	45552865
Powerstream 3 Phase Plus 21kW	P3PPE2102	45552866
Powerstream 3 Phase Plus 24kW	P3PPE2402	45552867
Powerstream 3 Phase Pipe Set	P3P 02RBS	87783163
Powerstream 3 Phase Mounting Set	P3P 02AP	87783164

Powerstream 3 Phase Plus Technical Specification

Powerstream 3 Phase Plus models	P3PPE1802	P3PPE2102	P3PPE2404
Rated power	18kW	21kW	24kW
Rated voltage	400V - 3 phase	400V - 3 phase	400V - 3 phase
Economy setting I			
1st stage	6kW	7kW	8kW
2nd stage	12kW	14kW	16kW
High setting II			
1st stage	9kW	10.5kW	12kW
2nd stage	18kW	21kW	24kW
Switch-on flow point			
1st stage	4.0 l/min	4.5 l/min	5.0 l/min
2nd stage	5.0 l/min	5.8 l/min	6.6 l/min
Mixed water at rated power (supply temp. 12 C)			
Approx. 38 C	9.9 l/min	11.6 l/min	13.2 l/min
Approx. 50 C	6.8 l/min	7.9 l/min	9.1 l/min
Minimum flow pressure of appliance			
With flow limiter	0.07 MPa (0.7bar)	0.08 MPa (0.8bar)	0.09 MPa (0.9bar)
Without flow limiter	0.04 MPa (0.4bar)	0.05 MPa (0.5bar)	0.06 MPa (0.6bar)
Operative range in waters of specific electric resistance at 15 C			
Rated pressure	1 MPa (10bar)	1 MPa (10bar)	1 MPa (10bar)
Maximum permissible supply temperature	20 C	20 C	20 C

Water Boiling Units Range Profile in Detail

Beverage Water Boilers

SB Professional Page 114		2.5-25 litre Stainless Steel Beverage Water Boilers 24 kW 2 yr GUARANTEED
SB ² Page 116		2.5-4 litre Beverage Water Boilers 22 kW 2 yr GUARANTEED
Corvette Page 118		1-3.8 litre Wall Kettle 22 kW 3 yr GUARANTEED

2.4
KW2 yr
GUARANTEEBEAB
APPROVED

Dimensions

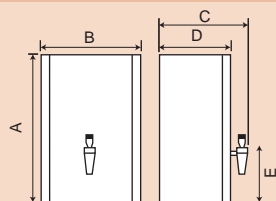

Water boiler variant	Dimensions (mm)				
	A	B	C	D	E
SB Pro. 2.5l	430	315	210	125	185
SB Pro. 5l, 7.5l	510	370	250	170	185
SB Pro. 10l, 15l	565	425	320	240	185
SB Pro. 20l, 25l	630	490	350	270	185

Technical Specification Connects to 13 Amp (220-240V) doublepole fused isolating switch | Electrical connection via 1 metre cable supplied to fused spur | Water entry bottom/rear via standard | 15mm compression fitting | Install over sink, draining board, or drip tray.

Product Range

Product Reference	Catalogue Number	Initial Draw Off (170ml)	(litres)	Recovery Rate (cups/hr)
SB Professional 2.5l	22713801	15	2.5	125
SB Professional 5l	22715801	30	5.0	125
SB Professional 7.5l	22716801	45	7.5	125
SB Professional 10l	22717801	60	10.0	125
SB Professional 15l	22718801	100	15.0	125
SB Professional 20l	22719301	120	20.0	125
SB Professional 25l	22719701	150	25.0	125

SB Professional

Stainless Steel Beverage Water Boilers

Wall-mounted, self-calibrating and self-filling this is a water heater for Industrial and Commercial applications. Used for making cups of tea, coffee, soup and hot snacks it offers 7 capacity sizes. The 2.5 litre model is ideal for small offices and the 25 litre model for a busy canteen, dispensing up to 150 cups on demand and a delivery of 250 cups per hour.

Application	Beverage water boiler.
Key Features	7 capacity options Stainless steel water tank with fully insulated jacket to minimise heat loss Robust corrosion resistant construction Provides for concealed plumbing and electrical connection.
Safety Features	Neon 'power on' light Condensation chamber for steam-free operation Manual reset thermostat for detecting excessive steam in the event of water solenoid valve failure Water temperature is automatically maintained Unit is fitted with manual reset safety device to avoid boiling dry.
Capacities	2.5, 5, 7.5, 10, 15, 20 and 25 litre.
Rating	2.4kW / 13 Amp (220-240V).
Outer Casing	Brushed stainless steel cover, wipes clean.
Insulation	Energy efficient aluminium backed insulation.
Water Container	Stainless steel.
Heat Unit	Incoloy sheathed elements.
Thermostat	Manual reset thermostat.
Pressure	Operating pressure - 2bar to 10bar.
Approvals	BEAB Approved CE.
Guarantee	2 year product guarantee (UK).

Storage Capacity (l)	1st hr Delivery (cups)	Element (kW)	Approx. Weight	App. Laden Weight
2.5	125	2.4	6kg	8.5kg
5.0	135	2.4	7kg	12kg
7.5	150	2.4	8kg	15.5kg
10.0	175	2.4	9kg	19kg
15.0	200	2.4	10kg	25kg
20.0	225	2.4	12kg	32kg
25.0	250	2.4	13kg	38kg



2.2
kW

2 yr
GUARANTEE

BEAB
Approved

CE

Dimensions

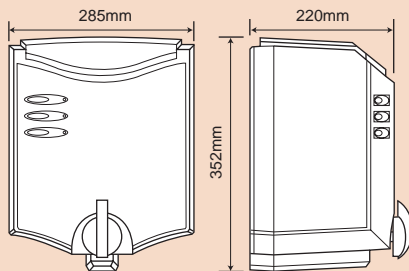

Technical Specification

Electrical connection from suitable ring circuit via a switched/fused outlet with 1 metre cable supplied | Wall-mounted with rear or bottom plumbing connection via a standard 15mm compression fitting to the cold water mains | Incorporates an overflow/vent connection that discharges to a suitable drain | Supplied with a hook-on wall bracket together with a 3-point screw fixing.

SB²

2.5 & 4 litre Beverage Water Boilers

Developed to deliver up to 154 cups of hot water every hour, this unique design provides drinks and beverages instantly without the need for kettles and minimising waiting times. Integral sensors give auto-fill/top-up and temperature control.

Application Beverage water boiling.

Key Features Auto-fill and heat | Push button for on/standby | Quarter turn tap to dispense water | Stainless steel sheathed heat elements for long-life | CFC-free insulation - minimises temperature and energy loss on/standby function for energy saving | Scale trap to enhance quality of beverage.

Safety Features Three LEDs indicate power on, unit full and temperature ready | Microprocessor controlled for water level and accurate temperature control | Thermostatically controlled to automatically set to boiling point when the unit is first switched on | Cool to the touch | Auto re-set over-temperature cut-out.

Capacities 2.5 and 4 litre.

Rating 2.2kW @ 240V.

Outer Casing High impact, durable thermoplastic.

Insulation CFC-free insulation.

Water Container High impact, thermoplastic.

Heat Unit Stainless steel elements.

Thermostat Electronic thermostat | Auto re-set over-temperature cut-out.

Pressure Supply pressure - min. 0.5bar (7psi), max. 10bar (145psi)

Approvals BEAB Approved | CE.

Guarantee 2 year product guarantee (UK).

Product Range

Product Reference	Short Code	Cat. No
SB2 2.5 litre	RSB 2.5	22714401
SB2 4 litre	RSB 4	22714601

2.2
KW3 yr
GUARANTEE

Dimensions

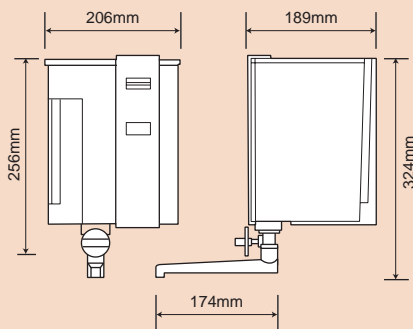

Accessories

Plumbing-in kit to connect the Corvette directly to the cold water mains (as pictured) | Extended length filler hose 1.7m | Extended length outlet spout 330mm | Tap adaptor kit to connect the filler hose to non-standard taps.



Technical Specification

Plumbing-in kit required for permanent supply | Electrical connection via a fused spur | Water entry via filler hose supplied, optional plumbing kit, or manually | Unit can be positioned over a sink or suitable outlet | Supplied 1m cable, cable tidy, wall mounting plate, wall fixing kit, 1m filler hose.

Corvette

1-3.8 litre Wall Kettle

The Corvette delivers boiling water for drinks and washing up needs, from a permanently wired installation.

Application	Beverage water boiling.
Key Features	Quick and easy installation Can boil from 1 litre to a maximum of 3.8 litres Easy to read water level indicator Detachable hose supplied for temporary installation Economical to use High quality stainless steel sheathed element Stainless steel base plate.
Safety Features	Auto switch off at boiling point Rapid reset Neon glows when water is being heated Extended spout for extra safe pouring Safety auto steam switch 2-stage boil dry element protection.
Capacities	1 to 3.8 litres.
Rating	2.2kW @ 240V.
Outer Casing	High impact, durable thermoplastic.
Water Container	High impact, thermoplastic.
Heat Unit	High quality stainless steel sheathed element.
Thermostat	Steam switch Auto re-set over-temperature cut-out.
Pressure	Mains pressure supply.
Accessories	See opposite page for details.
Approvals	CE.
Guarantee	3 year product guarantee (UK).

Product Range

Product Reference	Short Code	Cat. No
Corvette	CV1	28717201
Plumbing-in Kit		89716201
Extended Length Outlet Spout		89716203

Washrooms

Range Profile in Detail

Instantaneous Hand Washing

Autosensor



Page 124

Touch-free Vortex Spray Hand Wash Unit



Instant 3 & 7



Page 126

Vortex Spray Hand Wash Units



Automatic Hand Dryers

Turbo-Airflo



Page 128

High Velocity Automatic Hand Dryer



AD1 Autodry



Page 130

Compact Automatic Hand Dryers



AD10 Autodry



Page 132

Automatic Hand Dryers



AD20, 30 & 50 Autodry



Page 134

Automatic Hand and Face Dryers



Water Management

Autoflush



Page 136

Water Management



Washroom Solutions Selector

Choosing the right solution for your washroom is vitally important.

At **Redring**, customer support begins before you even buy! This selector should enable you to make a decision, but if you require assistance, please ring our customer techline on 0844 372 7766 for further information.

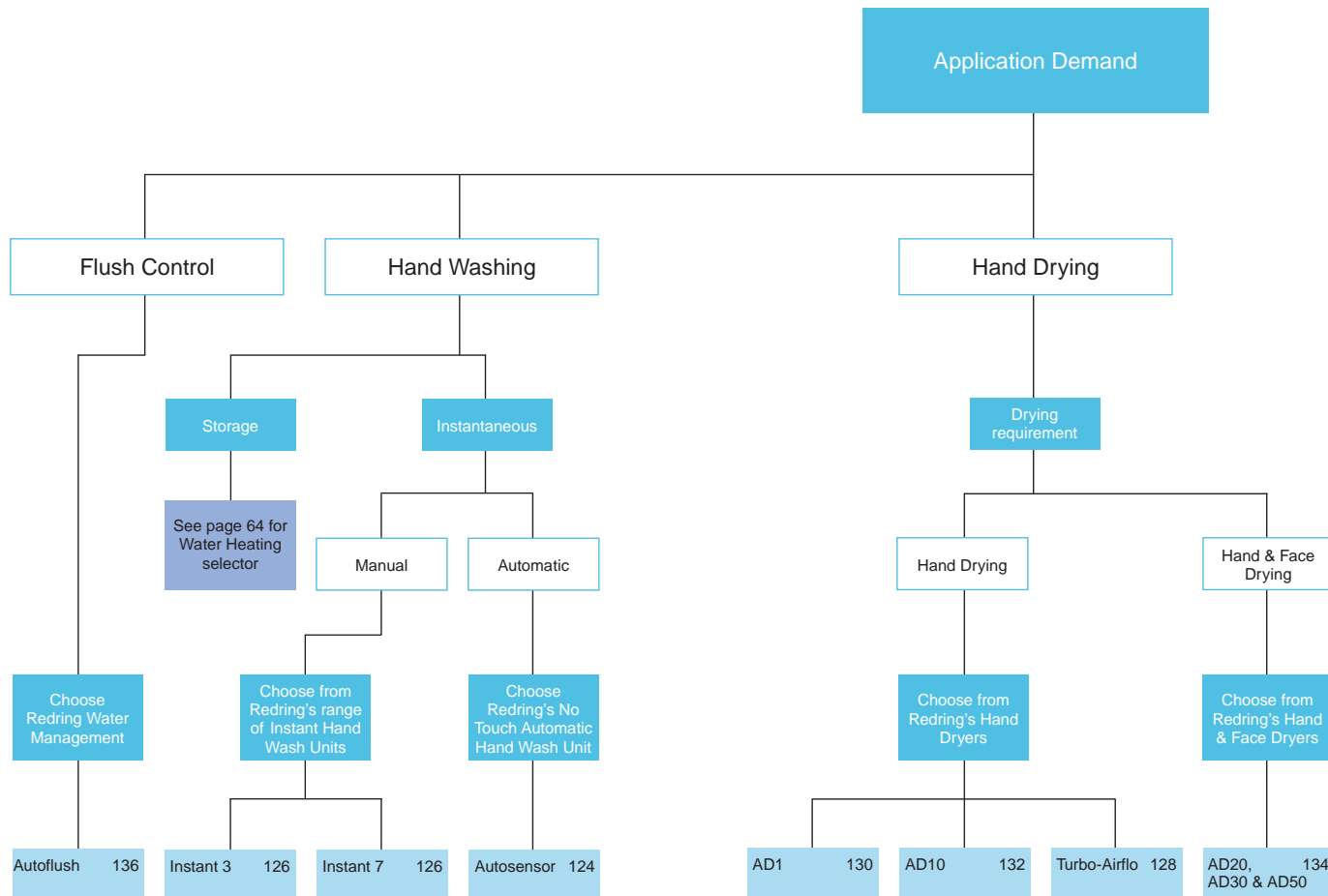



Vortex non-scale outlet

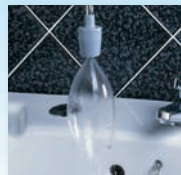

Dimensions

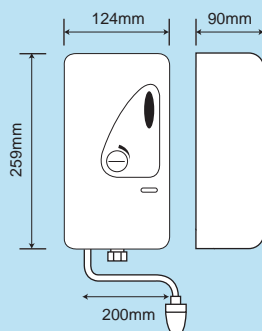

Technical Specification

Direct connections to water mains | Standard 15mm pipework | Top, bottom or rear cable entry | Standard BSP ½" connections | Full fixing pack supplied | Operating water pressure 0.7 - 7bar (10 - 100psi) | Water pressure operated power switch.

Product variant	kW loading @ 230-240V	Cable size guide	Fuse rating guide
AV3	3	1.5mm ²	13 amps

Autosensor

Touch-free Vortex Spray Hand Wash Unit

Ideal for environments where cross-contamination must be avoided, such as hospitals and food preparation areas, the Autosensor is a unique and patented hand wash unit, operated by a no-touch sensor. The unit is also fitted with a unique non-scaling vortex spray outlet and an automatic shut-off to eliminate waste water.

Application Hand washing.

Key Features Touch free hygienic operation prevents cross contamination | Infra-red sensor activates water output for economy | Compact ergonomic design | Solenoid valve on/off and recessed flow control knob to prevent unwanted flow adjustments | Vortex spray outlet is non-scaling and maintenance free | Swivel 200mm stainless steel spray arm | No standing heat losses | Touch-free time cycle cut-off 20 - 25 seconds.

Safety Features Fully temperature stabilised 'Heat on' LED indicator | Overheat protection | Timed shut-off set at approximately 20 seconds.

Rating 3kW @ 240V.

Controls Automatic no-touch infra-red sensor.

Outer Casing Easy clean | Polar white | Thermoplastic.

Heat Unit Sheathed heating elements.

Water Container Copper.

Ingress Protection IPX4.

Pressure Operating water pressure - 0.7 to 7bar (10 - 100psi).

Accessories Extended length spray arm - 380mm | Short length spray arm - 100mm.

Approvals BEAB Approved | CE.

Guarantee 3 year product guarantee (UK).

Product Range

Product Reference	Short Code	Cat. No
Autosensor	AV3	43591015
Ext. length spray arm, 380mm		85768322
Short length spray arm, 100mm		85768330

Instant 3 & 7

Vortex Spray Hand Wash Units

Economical and instant, these patented hand wash units are compact and simple to operate with a single on/off and temperature control lever. They are also fitted with our unique Vortex spray outlet which eliminates the need for costly maintenance due to the build-up of scale in hard water areas.

Application	Hand washing.
Key Features	Compact ergonomic design Single control lever for on/off and temperature selection Vortex spray outlet is non-scaling and maintenance free Swivel 200mm stainless steel spray arm No standing heat losses.
Safety Features	Fully temperature stabilised 'Heat on' neon indicator Overheat protection.
Rating	3kW and 7.2kW.
Controls	Single rotary control lever for on/off and temperature selection.
Outer Casing	Easy clean Polar white Thermoplastic.
Heat Unit	Sheathed heating element.
Water Container	Copper.
Ingress Protection	IPX4.
Pressure	Operating water pressure - 0.7 to 7bar (10 - 100psi).
Accessories	Extended length spray arm - 380mm Short length spray arm - 100mm
Approvals	BEAB Approved CE.
Guarantee	3 year product guarantee (UK).



Vortex non-scale outlet

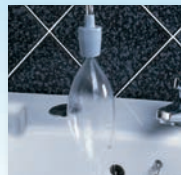

Dimensions

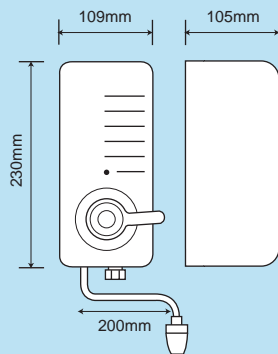

Technical Specification

Direct connections to water mains | Standard 15mm pipework | Top, bottom or rear cable entry | Standard BSP ½" connections | Full fixing pack supplied | Operating water pressure 0.7 - 7bar (10 - 100psi) | Water pressure operated power switch.

Product variant	kW loading @ 230-240V	Cable size guide	Fuse rating guide
IV3	2.7 - 3	1.5mm ²	13 amps
IV7	6.6 - 7.2	4/6mm ²	30 amps

Product Range

Product Reference	Short Code	Cat. No
Instant 3	I3V	43769715
Instant 7	I7V	43769915
Extended length spray arm		85768322
Short length spray arm		85768330



Dimensions

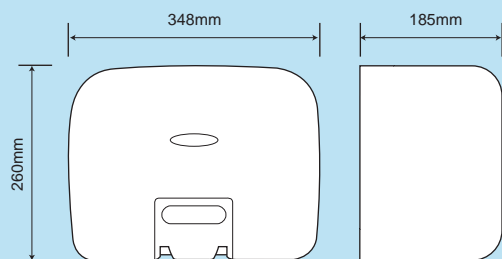

Technical Specification

Heating element closed coil nickel chromium wire | Sensor range 150mm | Peak air temperature rise (°C) 23 | Noise level at 1 metre (dBA) 78.

ADP1 Turbo-Airflo

High Velocity Automatic Hand Dryer

Hand dryers score significantly over paper towels as germ-free warm air is an extremely hygienic drying medium; with no risk of cross-infection between users. The all new Turbo-Airflo hand dryer improves on this by saving on both time and energy too, with its fast drying, high velocity airflow delivery. Approved by the Health and Safety Executive as well as the Ministry of Defence for use in commercial and office environments, it is also accepted by the National Health Service.

Application	Hand hygiene.
Key Features	High velocity airflow for fast drying Energy efficient, as fast dry times mean the unit is off more of the time Noise levels the same as standard dryers Fully automatic Light to medium use installations - ideal for food preparation areas, surgeries or clinics Easy clean Cover cast aluminium alloy with white epoxy paint Fast drying time - 15-22 seconds UK designed.
Safety Features	Ingress protection - IP23 Infra-red 'no touch' on/off sensor to prevent cross contamination Over-temperature cut-out.
Rating	1.7kW @ 240V.
Weight	5.8kg.
Outer Casing	Cover cast aluminium alloy with white epoxy paint.
Heat Unit	Heating element closed coil nickel chromium wire.
Motor / Fan	345W.
Air Speed	44m/s.
Air Volume	150 (m ³ /h).
Ingress Protection	IP23.
Approvals	CE.
Guarantee	3 year product guarantee (UK).

Product Range

Product Reference	Short Code	Cat. No
Turbo-Airflo	ADP1	56751801

2 yr
GUARANTEEBEAB
Approved

Dimensions

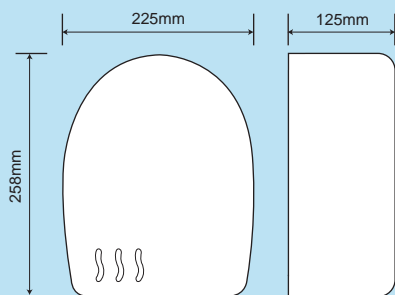

Technical Specification

Heating element closed coil nickel chromium wire |
Sensor range 150mm | Noise level at 1 metre (dBA) 63.

AD1 Autodry

Compact Automatic Hand Dryers

Germ-free warm air is an extremely hygienic drying medium; with no risk of cross-infection between users. Hand dryers are approved by the Health and Safety Executive as well as the Ministry of Defence for use in commercial and office environments. Also accepted by the National Health Service resulting in increasingly widespread use in British hospitals.

Application	Hand hygiene.
Key Features	Light/medium use installations - food preparation areas, surgeries or clinics Easy clean White and chrome options UK manufactured.
Safety Features	Infra-red 'no touch' on/off sensor to prevent cross contamination Ingress protection - IP24 Class II insulation, so no need to earth Over-temperature cut-out.
Rating	1.5kW @ 240V.
Weight	1.9kg.
Outer Casing	AD1 - White AD1Ch - Chrome plated thermoplastic.
Heat Unit	Heating element closed coil nickel chromium wire.
Motor / Fan	60W.
Air Speed	15m/s.
Air Volume	120m ³ /hr.
Ingress Protection	IP24.
Approvals	BEAB Approved CE.
Guarantee	2 year product guarantee (UK).

Product Range

Product Reference	Short Code	Cat. No
Autodry 1	AD1	56751501
Autodry 1 Chr	AD1Ch	56751570

AD10 Autodry

Automatic Hand Dryers

Hygiene is an area where warm air dryers score significantly over paper or linen towels. Germ-free warm air is an extremely hygienic drying medium; with no risk of cross-infection between users. Hand dryers are approved by the Health and Safety Executive as well as the Ministry of Defence for use in commercial and office environments. Also accepted by the National Health Service resulting in increasingly widespread use in British hospitals.

Application Hand hygiene.

Key Features Light/medium use installations - food preparation areas, surgeries or clinics | White, chrome and stainless steel options | UK manufactured | Easy clean | Fully automatic.

Safety Features Infra-red 'no touch' on/off sensor to prevent cross contamination | Ingress protection - IP21 | Class II insulation, so no need to earth | Over-temperature cut-out.

Rating 1.7kW @ 240V.

Weight 2.5kg.

Outer Casing **AD10** - White | **AD10Ch** - Chrome plated thermoplastic | **AD10S** - Stainless steel.

Heat Unit Heating element closed coil nickel chromium wire.

Motor / Fan 100W.

Air Speed 18m/s.

Air Volume 180m³/hr.

Ingress Protection IP21.

Approvals BEAB Approved | CE.

Guarantee 3 year product guarantee (UK).

3 yr
GUARANTEE

BEAB
Approved

CE

Dimensions

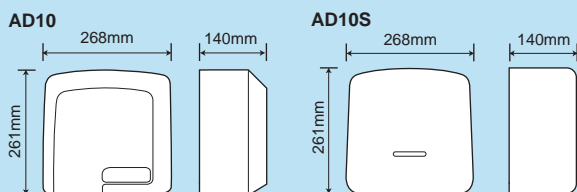

Technical Specification

Heating element closed coil nickel chromium wire | Sensor range 150mm | Noise level at 1 metre (dBA) 63.

Product Range

Product Reference	Short Code	Cat. No
Autodry 10	AD10	56750540
Autodry10Ch	AD10Ch	56750570
Autodry10S	AD10S	56750541

3 yr
GUARANTEEBEAB
Approved

Dimensions

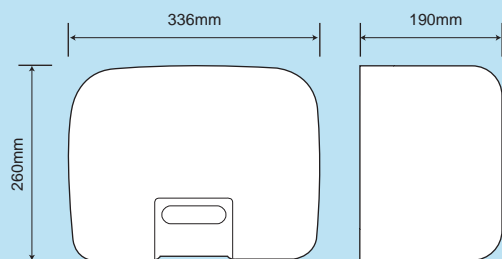

Technical Specification

Heating element closed coil nickel chromium wire |
Sensor range 150mm | AD20 Noise level at 1 metre (dBA) 64
| AD30 Noise level at 1 metre (dBA) 78 | AD50 Noise level at
1 metre (dBA) 78.

AD20, 30 & 50 Autodry

Automatic Hand and Face Dryers

With fully automatic operation the AD20 is ideal for installation where noise needs to be kept at a minimum, whilst the AD30 provides increased airflow for faster hand and face drying. For installation at the busiest washrooms we recommend the AD50.

Application	Hand and face hygiene.
Key Features	Hand and face drying Medium to high use installations (AD50C - High use) - ideal for motorway services, factories, schools & sports centres Easy clean Stainless & aluminium steel options White & chrome options UK manufactured Fully automatic AD20 Quiet operation AD30 Fast drying time AD50C High volume air-flow for faster drying.
Safety Features	Infra-red 'no touch' on/off sensor to prevent cross contamination Ingress protection - IP23 Over-temperature cut-out.
Rating	2kW @ 240V, 2.4kW @ 240V and 2.5kW @ 240V.
Weight	AD20 and AD30 - 6.5kg AD50C - 15kg.
Outer Casing	AD20 and AD30 cast aluminium epoxy paint. AD30 chrome, chrome cast aluminium chrome plated. AD50C cast iron vitreous enamelled.
Heat Unit	Heating element closed coil nickel chromium wire.
Motor / Fan	AD20 - 60W AD30 - 200W AD50 - 300W.
Air Speed	AD20 - 12m/s AD30 - 22m/s AD50 - 25m/s.
Air Volume	AD20 - 150 AD30 - 220 AD50 - 250m ³ /hr.
Ingress Protection	IP23.
Approvals	BEAB Approved CE.
Guarantee	3 year product guarantee (UK).

Product Range

Product Reference	Short Code	Cat. No
Autodry 20	AD20	56751303
Autodry 30	AD30	56751404
Autodry 30 Chrome	AD30Ch	56751470
Autodry 50C	AD50	56751118

Autoflush

Water Management

The Autoflush is a compact, unobtrusive automatic urinal flush controller which maintains hygiene whilst eliminating water wastage as required by Water Bylaw 83. Ideal for offices, public conveniences, hotels, restaurants, leisure facilities and factories, the Autoflush requires no electrical mains connection and is supplied with a dedicated long-life lithium battery.

Application Water management.

Key Features A powerful PIR sensor detects when someone approaches the urinals and switches a solenoid valve to open, allowing water to flush to the cistern | Typical water savings of over 70% per annum. Capital costs may be recouped in less than two years | Built-in cleansing flush (every 12 or 24 hours) for maximum hygiene during unoccupied periods | Choice of 10, 20 or 30 minute timed flow after detection (factory set to 30 minutes) | Red LED indicates when battery is low.

Safety Features No mains electrical connection required, long-life lithium battery supplied.

Rating Long-life lithium battery.

Controls PIR sensor.

Outer Casing Non-corrosive polar white ABS plastic box.

Ingress Protection IPX4.

Pressure Operating water pressure - 0.7 to 7bar (10-140psi).

Accessories Vandal-proof cover | Spare Battery.

Approvals Restrictors - WRAS | Valve - WRAS | Battery - UL | CE.

Guarantee 1 year product guarantee (UK).



Dimensions and Application

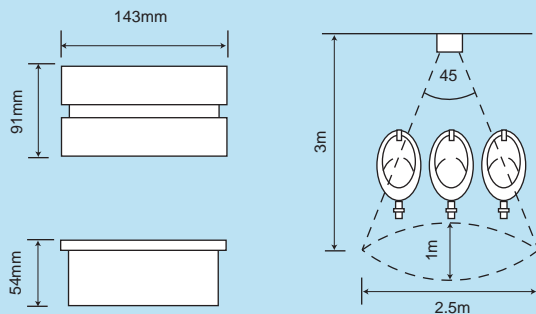

Technical Specification

NB: Water Bylaw 83 states that where urinals are installed there must be a method of controlling the flushing, preventing inflow during times when they are not being used | Note 2 - Designed to be used with a cistern. Unsuitable for pressurised systems | Water connections - 15mm compression | Recommended cable - 2 core, CSA 0.5mm² (Outer diameter 5.4mm).

Product variant	Sensor	Sensor range	Battery pack supplied	Solenoid valve
AF1	Passive infra-red	Up to 4m	10.5V, 3.6Ah lithium long-life	9V DC latching (0-12bar)

Product Range

Product Reference	Short Code	Cat. No
Autoflush	AF1	27900001
Spare battery	BAT	96900102

Technical Tables

Temperature Conversion Table

°C	°F
1	33.8
5	41.0
10	50.0
15	59.0
20	68.0
25	77.0
30	86.0
35	95.0
40	104.0
45	113.0
50	122.0
55	131.0
60	140.0
65	149.0
70	158.0
75	167.0
80	176.0
85	185.0
90	194.0
95	203.0
100	212.0

Pressure Conversion Table

Head Feet	Pressure llb / in ²
1	0.4
2	0.9
3	1.3
4	1.7
5	2.2
6	2.6
7	3.0
8	3.5
9	3.9
10	4.3
11	4.8
12	5.2
13	5.6
14	6.1
15	6.5
16	6.9
17	7.4
18	7.8
19	8.2
20	8.7
21	9.1
22	9.5
23	10.0
24	10.4
25	10.8

Pressure Conversion Table (continued)

Head Feet	Pressure llb / in ²	Head Feet	Pressure llb / in ²	Head Feet	Pressure llb / in ²
26	11.3	51	22.1	76	32.9
27	11.7	52	22.5	77	33.4
28	12.1	53	23.0	78	33.8
29	12.6	54	23.4	79	34.2
30	13.0	55	23.8	80	34.7
31	13.4	56	24.3	81	35.1
32	13.9	57	24.7	82	35.5
33	14.3	58	25.1	83	36.0
34	14.7	59	25.6	84	36.4
35	15.2	60	26.0	85	36.8
36	15.6	61	26.4	86	37.3
37	16.0	62	26.9	87	37.7
38	16.5	63	27.3	88	38.1
39	16.9	64	27.7	89	38.6
40	17.3	65	28.2	90	39.0
41	17.8	66	28.6	91	39.4
42	18.2	67	29.0	92	39.9
43	18.6	68	29.5	93	40.3
44	19.1	69	29.9	94	40.7
45	19.5	70	30.3	95	41.2
46	19.9	71	30.8	96	41.6
47	20.4	72	31.2	97	42.0
48	20.8	73	31.6	98	42.5
49	21.2	74	32.1	99	42.9
50	21.7	75	32.5	100	43.4

Required Hot Water Requirements

Handwashing	1 to 2.5 litres per person (40°C)
Kitchen sink	2 to 7 litres per person (60°C)
Cleaning	10 litres per day (60°C)

Required Hot Water Requirements (continued)

Bath	60 litres per bath (60°C)
Hairdressing	10 litres per shampoo (40°C)
Dishwasher	2 litres per meal (60°C)

Technical Tables

Standard Formulae

Loading Calculations (excluding heat losses)

$$\text{Time to heat water (mins)} = \frac{\text{Litres x Temp rise (}^\circ\text{C)}}{\text{kW loading x 14.3}}$$

$$= \frac{\text{Gallons x Temp rise (}^\circ\text{F)}}{\text{kW loading x 5.7}}$$

$$\text{kW loading required} = \frac{\text{Litres x Temp rise (}^\circ\text{C)}}{\text{Time (mins) x 14.3}}$$

$$= \frac{\text{Gallons x Temp rise (}^\circ\text{F)}}{\text{Time (mins) x 5.7}}$$

Performance Calculations

$$\text{Litres per minute flow} = \frac{\text{kW loading x 14.3}}{\text{Temp rise (}^\circ\text{C)}}$$

$$\text{Temp rise }^\circ\text{C} = \frac{\text{kW loading x 14.3}}{\text{Litres per min flow}}$$

$$\text{Temp rise }^\circ\text{F} = \frac{\text{kW loading x 5.7}}{\text{Gallons per min flow}}$$

$$\text{kW loading required} = \frac{\text{Litres x Temp rise (}^\circ\text{C)}}{\text{Time (mins) x 14.3}}$$

Hot Water Recovery Chart

Loading Kilowatts	Litres of Water							
	5	7	10	15	30	60	80	100
1.0	18	25	35	55	105	210	280	
2.0	9	13	18	27	55	105	140	175
3.0	6	9	12	18	35	70	95	120
4.0	5	7	9	14	27	55	70	90
6.0	3	5	6	9	18	35	50	60
8.0	3	4	5	7	14	27	35	45
9.0	2	3	4	6	12	24	31	49
12.0	2	2	3	5	9	18	24	30
15.0	2	2	3	4	7	14	19	24

Physical Constants

Length **1m** = 3.28ft
1ft = 30.8cm

Volume **1gal** = 4.54l
= 277 cu. ins.
= 10lbs (water)
1litre = 0.22gals
= 1000cm³
= 1kg (water)
1000l = 1m³

Weight **1lb** = 0.45kg
1kg = 2.21lbs

Pressure **1bar** = 14.5psi = 100kN/m²
1ft head of water = 0.434psi
1m head of water = 9.8kN/m²

1 joule = 1 watt second (Ws)

1 kW hour = 3412 Btu
= 860kcal

1 British Thermal Unit (Btu) = heat required to raise 1lb water through 1°F
= 17.6 watt mins
= 0.252kcal

1 kilocalorie (kcal) = Heat required to raise 1kg water through 1°C
= 4187Joules
= 3.97Btu

Hot Water Recovery Chart (continued)

Loading Kilowatts	Litres of Water							
	150	200	250	300	400	600	800	1000
1.0								
2.0	265							
3.0	175	235	295					
4.0	135	175	220	265				
6.0	90	120	150	175	235	350	470	585
8.0	70	90	110	135	185	265	350	440
9.0	60	80	100	120	160	235	315	390
12.0	45	60	75	90	120	175	235	295
15.0	35	50	60	70	95	140	190	235

Approvals and Associations

Waste Electrical and Electronic Equipment Directive

Redring can confirm that all our responsibilities under the Waste Electrical and Electronic Equipment Directive will be fulfilled in accordance with the law. As required within its provisions we are members of an accredited WEEE recycling scheme for all product categories within the scope of the directive.

WEEE product registration number: WEE/EE0202VV.



Electric showers approved to BEAB CARE standard for thermostatic performance in care establishments.



The BEAB Approved Mark is the electrical safety mark of the UK's leading independent approvals specialists. It confirms to all in the supply chain that all products displaying the mark have been evaluated to the highest European and International safety standards.



Redring products are CE marked where necessary to certify that the product fulfills the requirements of all relevant European product directives.



Products approved for connection to the water mains supply.



Inclusive Design Approved - following independent testing. Suitable for all sections of the community.



UK Sales

Sales Hotline 0844 372 7750

Sales Fax 0844 372 7760

Technical Services

Techline 0844 372 7766

Techfax 0844 372 7767

International Sales

Redring is a great British brand in every sense of the word. It is also a world leader in showering and hot water solutions, demanded in over twenty countries worldwide. Redring has achieved this by taking into consideration global market requirements and ensuring products are developed to meet these needs, as well as developing products for specific countries and regions, taking into consideration approvals, electrical supply and climate. For further details call:

Sales Hotline +44 (0) 1733 456789

Sales Fax +44 (0) 1733 456727

All Redring products, unless otherwise stated, are covered by a full parts and labour guarantee for 1 year from the date of purchase, so should the product become faulty within the guarantee period, it will be replaced with a new product or repaired by our service engineers, totally free of charge.

Redring reserve the right to alter product specification or appearance without prior notice. All finishes in the brochure are as accurate as printing processes allow.

06/2011 Applied Energy Products.
All rights reserved

applied energy

Applied Energy Products Ltd
Morley Way
Peterborough
PE2 9JJ

t +44 (0) 844 372 7761

f +44 (0) 844 372 7762

www.redring.co.uk

info@redring.co.uk



www.youtube.com/user/redringsolutions



www.twitter.com/redringsolution