

Product Code: OVEM5311WHDST

Description: 4W Emergency LED Self-Test Box Maintained Sign - White - Down Legend

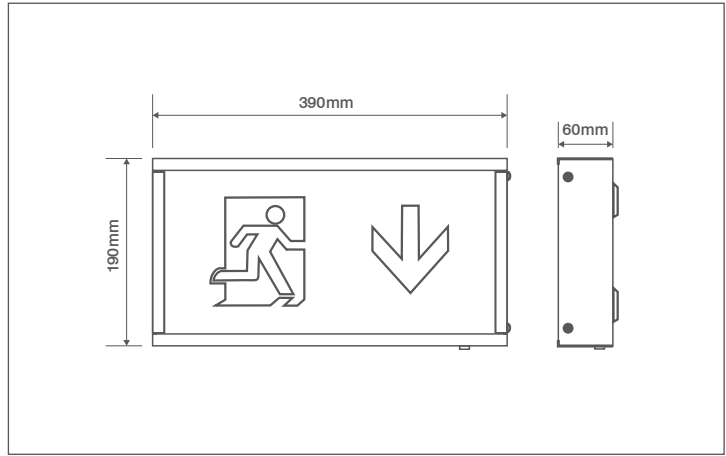

General Information

| | |
|--------------------|--|
| Dimensions | 390mm (W) x 190mm (H) x 60mm (D) |
| Materials | Housing: Powdercoated Steel Sign: Acrylic |
| Finish | White |
| Weight | 1.5Kg |
| Ingress Protection | IP20 |
| Self-Test Facility | Yes |
| Warranty | 4 Years |

Luminaire Output

| | |
|-------------------------|--------------|
| Colour Temperature | 5500K |
| LED Lifetime (L70) | 30,000 Hours |
| Beam Angle | 100° |
| Typical Luminous Flux | 45lm |
| Emergency Luminous Flux | 40lm |
| Viewing Distance | 34 Metres |
| Legend Direction | Down |

Supply & Power

| | |
|---------------------------|------------------------------|
| Input Voltage & Frequency | 220-240V ~ 50/60Hz |
| Electrical Safety | Class I |
| Input Power | 4W |
| Operation Mode | Maintained or Non-maintained |
| Ambient Temperature (Ta) | 0°C - +40°C |
| Critical Temperature | +70°C |
| Cable Entry | 2 x 20mm Diameter Knockouts |

Emergency Information

| | |
|-----------------------|---------------------------------------|
| Emergency Duration | 3 hours minimum |
| Charging Time | 24 Hours |
| Battery Specification | 3.6V 1500mAh Ni-Cd Battery - Parallel |

Replacement Battery

| | |
|--------------|---------------------------------------|
| OVEMB3615NCP | 3.6V 1500mAh Ni-Cd Battery - Parallel |
|--------------|---------------------------------------|