

SLATE BACKLIT

Technical Specification

Product Code: OV74301CWB

Description: 30W 600mm x 600mm Backlit LED Panel CW White

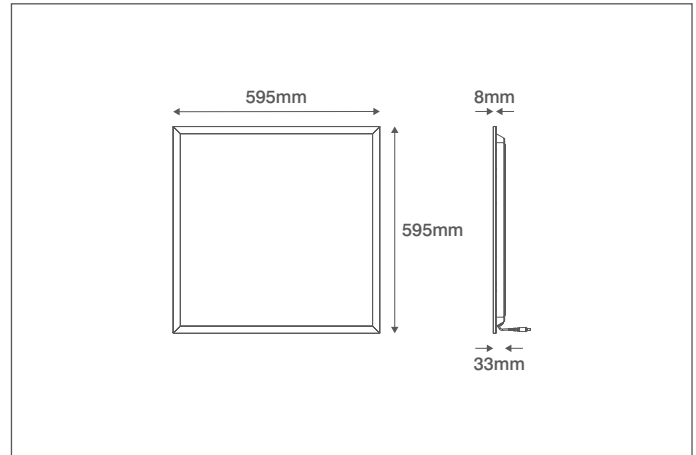

General Information

Dimensions (mm)	595 (L) x 595 (W) x 33 (D)
Materials	Frame: Powdercoated Aluminium Diffuser: Polystyrene Back Cover: Powdercoated Steel
Finish	White (RAL 9003)
Product Weight (Kg)	1.8
Ingress Protection	IP20
Impact Rating (IK)	06
Flammability Rating	TP(b)
Warranty (Years)	5

Additional Information

Suspension hooks pre-fitted to the back

Compatible Accessories

- OVCGMF0001 - 240V~ 29-48W Multi-function Dimmable Constant Current LED Driver (36W Setting)
- OVSUSP731 - Suspension Wire Kit
- OVREC731 - 600mm x 600mm Recess Frame Kit
- OVSURF734 - 600mm x 600mm Surface Frame Kit
- OVEMCG50 - 3 Hour Emergency Pack
- OVEMCG50ST - 3 Hour Self-Test Emergency Pack

Supply & Power Information

Input Voltage & Frequency (V~ / Hz)	200-240 50
Safety Class	II
Circuit Wattage (W)	30
Input Current (mA)	125
Inrush Current/Time	<40A (350uS@220V~)
Power Factor	>0.9
Operating Temperature (°C)	-25 to +40
Critical Temperature (°C)	+90
Driver Information	Remote Driver Supplied
Prewired Flow™ Connector	3 Pole CT105-F Push-fit Terminals

Luminaire Output

Colour Temperature (K)	4000
Colour Render Index (CRI)	>80
Typical Luminous Flux (lm)	3100
Efficacy (lm/W)	105
Beam Angle (°)	120
LED Lifetime (L70) (Hours)	50,000

Dimming Information

Dimmable	No
----------	----

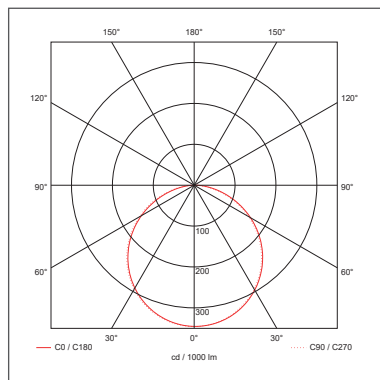

OVIA Limited, Scolmore House, Mariner, Lichfield Road Industrial Estate, Tamworth, Staffordshire, B79 7UL United Kingdom

T: +44 (0)1827 300640

E: sales@oviaUK.com | W: oviaUK.com