

DATA SHEET:

GDM010BC/ GDM010MW/ GDM010PC/ GDM010U/ GDM010MB

ISSUE: AVOC19VOL3

20AX DP key module

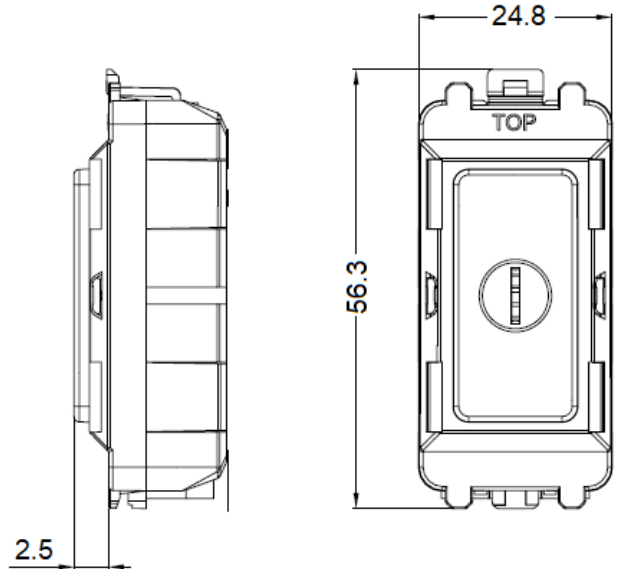

MLA part code	GDM010BC	GDM010MW	GDM010PC	GDM010U	GDM010MB
Description	20AX double pole key module				
Finish	Brushed chrome	Matt white	Polished chrome	White	Matt black
Nett weight (kg)	0.023				
Dimensions (mm)	Width – 24.8 Height – 56.3 Projection – 2.5				
Input voltage	Mains 230V 50Hz				
Min. mounting depth (mm)	35				
Maximum load (A)	20AX				
IP rating	IP20				
Terminal capacity	3 x 2.5mm or 2 x 4.0mm				
Construction	Steel & ABS				
Warranty	15 years				
Origin of Manufacture	China				
Declaration of Conformity (held on file)	Yes				
Manufactured in accordance with	BS EN 60669-1				
EAN	5055832963790	5055832963806	5055832963813	5055832963820	5056270800906