

20AX 2-way SP key module

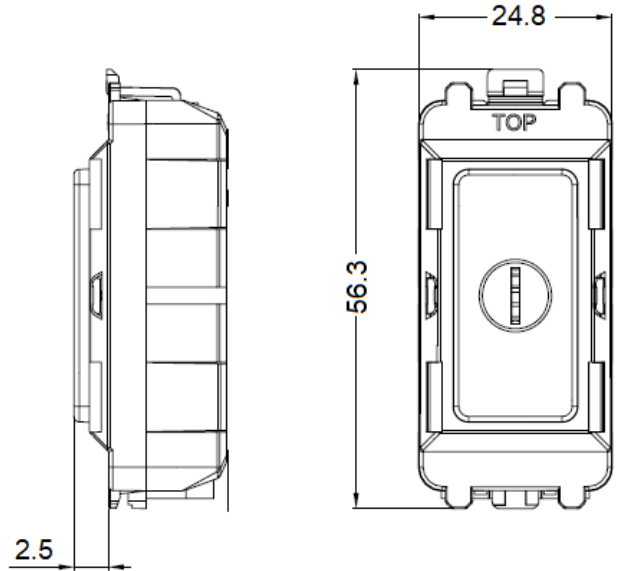

MLA part code	GDM009BC	GDM009MW	GDM009PC	GDM009U	GDM009MB
Description	20AX 2-way single pole key module				
Finish	Brushed chrome	Matt white	Polished chrome	White	Matt black
Nett weight (kg)	0.023				
Dimensions (mm)	Width – 24.8 Height – 56.3 Projection – 2.5				
Input voltage	Mains 230V 50Hz				
Min. mounting depth (mm)	35				
Maximum load (A)	20AX				
IP rating	IP20				
Terminal capacity	3 x 1.5mm or 2 x 2.5mm				
Construction	Steel & ABS				
Warranty	15 years				
Origin of Manufacture	China				
Declaration of Conformity (held on file)	Yes				
Manufactured in accordance with	BS EN 60669-1				
EAN	5055832963752	5055832963769	5055832963776	5055832963783	5056270800876