

## LED LuxPanel

### 300mm x 300mm

Edgelit White Frame

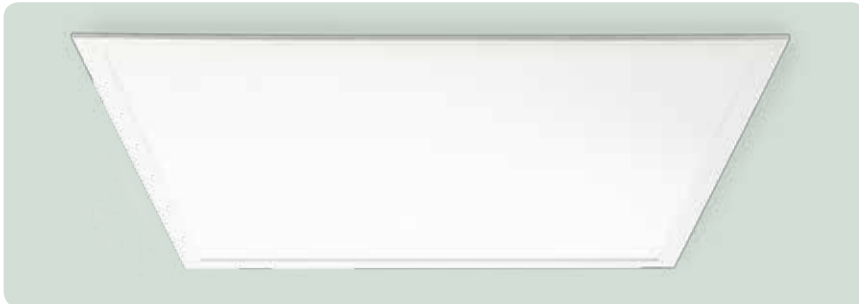

- Remote “plug and play” style driver, supplied in standard, dimmable or emergency options
- Maintenance free panel
- Epistar LED and Tridonic Driver

[Click here for more information](#)

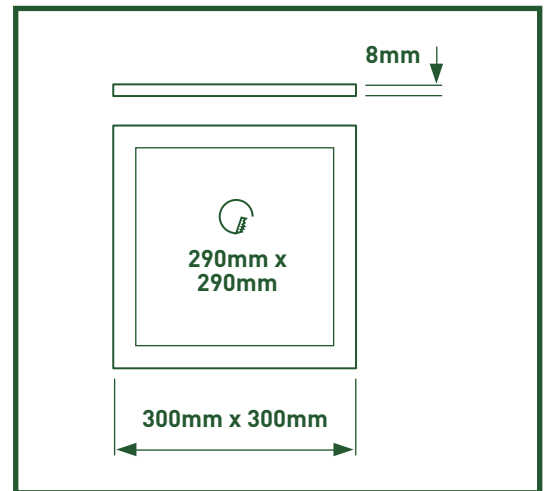

5 years extended (3 years standard) guarantee and 1 year onsite warranty available in the UK. Rest of the world may vary, please ask your local distributor for more information.



4800K ‘neutral white’ colour temperature as standard; other colour temperatures available to order, subject to minimum requirement - 3000K / 4000K / 6000K

Cat No	Description	Frame Colour	Voltage	Barcode
LP30W8S48	Standard driver	White	230V	5015056527130
LP30W8D48	Dimmable driver	White	230V	5015056527154
LED3EP80-OJ	Emergency pack	-	-	5015056539089



#### Standards

EN 60598-1	Luminaires - General requirements
EN 60598-2-2	Luminaires - Recessed
EN 61347-1	Lamp controlgear - Part 1: General and safety requirements
EN 61347-2-13	Lamp controlgear - Part 2-13 : Particular requirements for d.c. or a.c. supplied electronic controlgear for LED modules
EN 55015	Limits and methods of measurement of radio disturbance characteristics of electrical lighting and similar equipment
EN 61000-3-2	Electromagnetic compatibility (EMC) - Part 3-2: Limits - Limits for harmonic current emissions
EN 62471	Photobiological safety of lamps and lamp systems
2002/96/EC	Waste Electrical & Electronic Equipment (WEEE)
2011/65/EU	Restriction of the use of certain Hazardous Substances in EEE (RoHS)
(EC) No 1907/2006	The Registration, Evaluation, Authorisation and Restriction of Chemicals (REACH)
EN 61547	Equipment for general lighting purposes - EMC immunity requirements

### LUCECO

The luminaire contains built-in LED lamps.

The lamps cannot be changed in the luminaire.

874/2012

Tech Help Line  
 UK - **0845 194 7584**  
 Non UK - **+44 (0)1952 238 100**

Supplied by Nexus Industries Ltd  
 Nexus Distribution Centre, Stafford Park 1  
 Telford, Shropshire, TF3 3BD

Visit our website at

[www.luceco.uk](http://www.luceco.uk)